

# Service Manual

**Haldex**

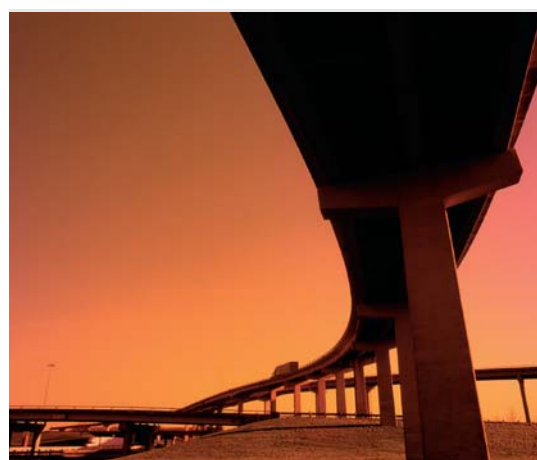

## AIR DISC BRAKE ModuIT



---

<b>Disclaimer</b>	<b>2</b>
<b>1 Introduction</b>	<b>3</b>
1.1 General Information.....	3
1.2 The Haldex ModulT.....	4
1.3 Functional Description.....	5
<b>2 Safety Precautions</b>	<b>6</b>
2.1 General Information.....	6
2.2 Installation.....	6
2.3 Adjustment of Control System/Valves .....	7
2.4 Brake Chamber .....	8
2.5 Recycling .....	8
2.5 Cleaning.....	8
2.6 Surface finishing for Disc Brake .....	9
<b>3 Initial and Final Procedures</b>	<b>10</b>
3.1 General Information.....	10
3.2 Initial Procedure.....	10
3.3 Function Test .....	12
3.4 Final Procedure.....	14
<b>4 Inspection Procedures</b>	<b>16</b>
4.1 General Information.....	16
4.2 Inspection intervals .....	16
4.3 Inspections .....	17
<b>5 Replacement Procedures</b>	<b>30</b>
5.1 General Information.....	30
5.2 Replacement of Brake Pads .....	30
5.3 Replacement of Brake Chamber.....	36
5.4 Replacement of Adjustment Screw Bellows .....	41
5.5 Replacement of Slide Function Assembly .....	46
5.6 Replacement of Reset Shaft Complete .....	57
5.7 Replacement of Disc Brake .....	59
<b>6 Specifications</b>	<b>61</b>
6.1 Wear Limits.....	61
6.2 Tightening Torques.....	61
<b>7 Tools</b>	<b>62</b>
7.1 Haldex ModulT Tool Kit complete .....	62
7.2 Special tools for Haldex ModulT. ....	63
<b>8 Fault Finding</b>	<b>64</b>
<b>9 Component List and Exploded view</b>	<b>66</b>
9.1 Component List .....	66
9.2 Exploded view.....	67

## Please note

This Service Manual is intended for the exclusive use by trained persons within the commercial vehicle industry and related workshops.

The content of this manual is not all-inclusive and not legally binding and Haldex Brake Products AB assumes no liability as a result of its use. All information contained in the manual does neither represent ensured characteristics of the product nor represent a guarantee. Haldex Brake Products AB reserves the right to make changes in the interest of technical progress without prior notice.

No liability is assumed as a result of incorrect or inappropriate parts being fitted to the product or the omittance of appropriate tests after the servicing of the product. Use appropriate spare parts' documentation when obtaining spare parts. Use only genuine Haldex spare parts in repairs.

This manual is subject to a copyright of Haldex Brake Products AB that reserves all rights. No part of this manual may be reproduced, copied or translated in any form or by any means without the prior written permission of Haldex Brake Products AB. Brand names mentioned in this manual are not identified as such in all cases, but they nevertheless are subject to the provisions of trademark legislation.

In case of conflicting language versions of this manual, the English original prevails.

The failure of any individual provision of this disclaimer to comply with current legal provisions does not affect the validity of the remaining provisions.

# 1 Introduction

## 1.1 General Information

This Haldex ModulT Service Manual is divided up into chapters, these chapters are sequenced in the same way that a user should read and follow the manual.

Chapter "1. Introduction" provides a general overview of this service manual and the ModulT disc brake.

It is important to carefully read chapter "2. Safety Precautions" before starting any workshop procedures. This is to inform the user about the safety measures and the potentially hazardous situations which, if not avoided, could result in serious injury or death!

Chapter "3. Initial and Final Procedures" describes the start and finish activities necessary to be able to carry out inspection and replacement work. It also describes the function test for the ModulT disc brake.

Consult chapter "4. Inspection Procedures" for information and instruction on inspecting the ModulT disc brake. Chapter "4.2. Inspection Intervals" is useful for the recommended disc brakes inspection intervals. Here the Inspection Intervals table displays how frequent the different brake components shall be inspected and on which pages the check instructions are to be found.

If any inspection shows that a replacement activity needs to be performed, continue to the appropriate section in chapter "5. Replacement Procedures".

Chapter "6. Specifications" contains technical data for the ModulT disc brake.

Chapter "7. Tools" contains information about the Haldex ModulT Tool Kit, which is essential for carrying out much of the replacement procedure work described in this manual.

Chapter "8. Fault Finding" should be used to help with the self diagnosis of any problem being experienced.

Finally Chapter "9. Components List" lists and shows what spare part components are available for the ModulT disc brake.

### 1.1.1 Spare Parts

It is vital that only Haldex original spare parts are used during all service replacement activities.

The use of none Haldex original spare parts can affect the function, performance and/or lifetime of the parts.

The use of none Haldex original spare parts will immediately terminate any warranty of the disc brake unit.

## 1.2 The Haldex ModulT

The Haldex ModulT is an air disc brake platform developed for the purpose of meeting increased customer demands on performance, robustness, service up-time and weight.

The ModulT superior design encompasses the following advantages:

- Low weight;
- Single tappet mechanism with similar clamping force distribution as Haldex twin tappet mechanism;
- Simplified maintenance; boltless pad retainer and only two bolts in the complete brake;
- Modular; the same mechanism and sliding function design used on multiple brake sizes;
- Long service life; stainless sliding pins, PTFE coated steel bushings, and the mechanism bellows is folded inwards thus protected from external affection (stones/blister etc.);
- High efficiency; the use of double roller bearings for the mechanism lever keeps the hysteresis low and thus a high efficiency is achieved.

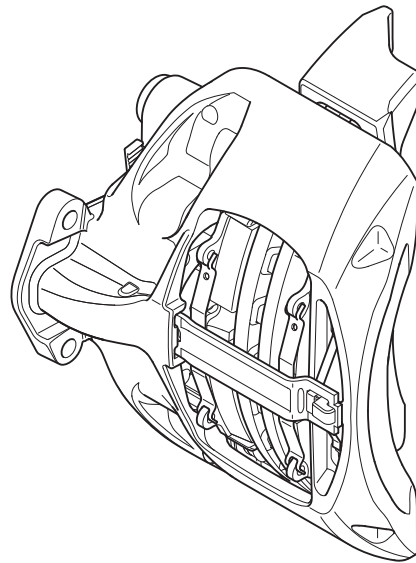

ModulT\_063

Figure 1. The Haldex ModulT Disc Brake

## 1.3 Functional Description

The ModulT is designed to provide high performance coupled with low weight, durability and a minimum number of wearing parts.

The ModulT enhances a floating monobloc calliper (C) and an integrated adjustment unit which compensates for brake pad wear.

The unit, which is actuated by the mechanism lever (A), presses the inner brake pad (B) against the disc, which then causes the calliper (C) to slide laterally, so that the outer brake pad (D) also comes in contact with the disc, see figure 2.

The calliper moves on slide pins (E), see figure 3. Where the disc brake also serves as a parking brake, the unit is actuated by a spring brake chamber (F).

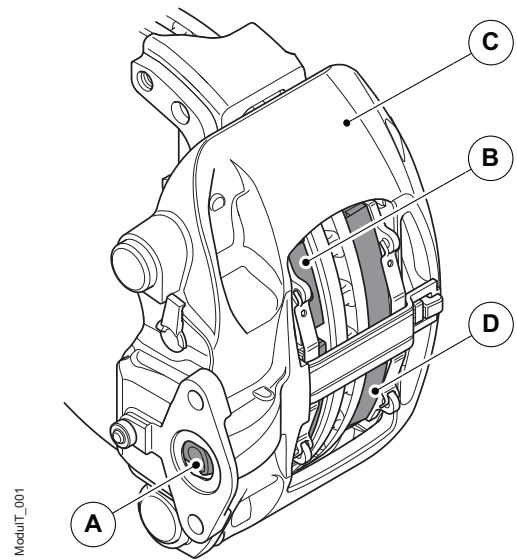

Figure 2. Functional description

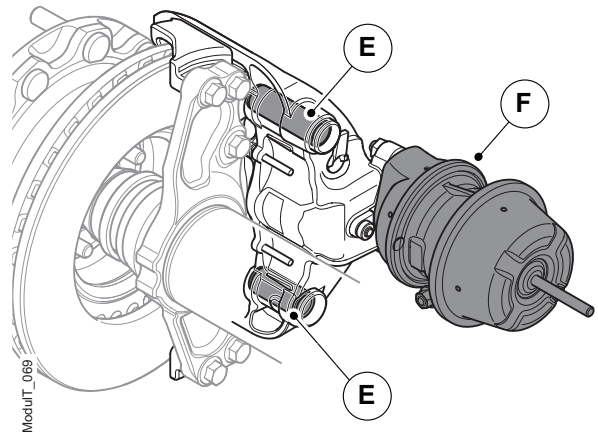

Figure 3. Slide pins and spring brake chamber

## 2 Safety Precautions

### 2.1 General Information

This chapter comprehends the Safety Precautions that shall be read and followed before any Inspection/Removal/Installation procedure described in this Service Manual is started.

This Service Manual is intended for the exclusive use of trained persons within the commercial vehicle industry and related work shops.

Three different alert levels are used through out this Service Manual: Warning, Important and Note.

Their differences are explained below:



**A Warning message is always accompanied by a safety alert symbol. The safety alert symbol is used to alert about potential personal injury hazards. To avoid hazards, obey all safety messages that follow this symbol. Failure to observe this information can cause serious personal injury or death!**

#### **IMPORTANT!**

**An important message is always accompanied by the signal word IMPORTANT! The Important sign means risk of damage to the brake! Failure to observe this information could result in damage to the whole brake or parts of it!**

#### **NOTE!**

**A notification message is always accompanied by the word NOTE! The Note sign is used to emphasize important information and is not to be regarded as hazard information.**

### 2.2 Installation

The disc brake must not be installed or treated in such a way that exposes it to none normal thermal, mechanical or chemical influences that can cause reduced braking effect or damage to vital components in the brakes. These influences/damages may result in a shortened service life for the disc brake and its components, reduced brake effect or at worst total brake failure.

## 2.3 Adjustment of Control System/Valves

Failure to follow the instructions in this chapter may accelerate the wear to the brake pads and may cause damage/repeated damage to the disc brake, axle and/or wheel brake components.

### 2.3.1 Before entering the Vehicle into service

Prior to first time use a vehicles disc brake operating systems must be checked and adjusted (if necessary) in accordance with the relevant brake calculations. Contact the vehicle manufacturer for relevant information.

### 2.3.2 Replacing Spare Parts

Always use spare parts that are approved for the vehicle, axle or disc brake. Following replacement of any essential components or spare parts in the disc brake operating system (such as brake valves or control units), the disc brake operating system must also be checked and adjusted (if necessary) in accordance with the relevant braking calculations.

### 2.3.3 Brake Force Distribution

It is very important that the distribution of brake force, between axles/vehicles, in a vehicle combination is adapted so that the brake force for each axle/vehicle is proportioned in accordance with the legally applied braking calculations.

If the brake force is not correctly distributed it can lead to excessive braking of a vehicle and/or one or more axles in the combination. This can result in overheating, accelerated wear and damage to the disc brake, pads, discs, tyres and wheel components.

Before a vehicle is entered into service it must be set up according to the specified values in the relevant brake calculations. After the pads/brake discs have been run in for a period of around 3,000-5,000 km the brake force distribution between the truck/tractor and trailer may require adjustment. Brake adjustment must also be carried out during repairs/changing spare parts when heating/overheating has suspected to damaged the axle/brake components (e.g. rubber components, hub/wheel bearings and brake disc).

Contact the vehicle supplier for information on the appropriate action.

Following replacement of any essential components or spare parts in the disc brake operating system (e.g. brake valves or control units), the disc brake operating system must also be checked and adjusted in accordance with the relevant braking calculations.

Failure to follow these instructions may cause damage/repeated damage to the disc brake, axle and/or wheel brake components.



## 2.4 Brake Chamber

Moisture/water ingress into the disc brake's mechanism housing will potentially affect the function of the disc brake and as a result shorten its life.

Therefore, to prevent water ingress it is important that the disc brake chamber is of the correct design and that the seal between the brake chamber and disc brake mating surface is undamaged correctly in place.

It is also important for the disc brake's function that the brake chamber housing is correctly ventilated.

As a minimum, the drain holes facing downwards must be open, see figure 4. Other drain plugs can remain in position in the brake chamber housing.

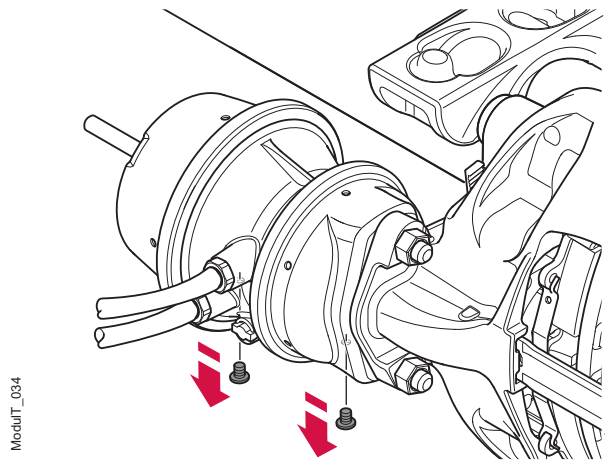

Figure 4. Brake chamber ventilation

### **IMPORTANT!**

**If all the plugs remain fitted, the brake chamber and disc brake will not operate correctly!**

## 2.5 Recycling

When replacing the disc brake or parts thereof, the components removed must be recycled/destroyed in compliance with applicable environmental legislation, regulations and provisions.

## 2.6 Cleaning

For the disc brake to function correctly it is important to ensure it is kept clean and that its normal movements are not restricted by mud, ice, snow, objects, etc. Damage may cause direct brake failure or damp/dirt penetration resulting in malfunction/shortening of the service life of the disc brake.

### **IMPORTANT!**

**It is important to take care when using chemicals and/or cleaning tools (e.g. knife, brush, etc). This to avoid damage or displacement of hoses, seals and other components.**

## 2.7 Surface finishing for Disc Brake

### 2.7.1 Painting

The disc brake can be finished with paint that has trade approval for this purpose (automotive paint). Care must be taken to ensure that the paint layer does not cause damage and/or restrict the natural movement or operation of the disc brake. All contact surfaces, friction and rubber parts must therefore be protected or masked.

The following areas must not be painted:

All bellows, Reset Shaft and its protection Plug, complete Brake Pads, the swept area of the disc, the disc brake mounting surfaces to axle/brake chamber and all bolted connections.

### 2.7.2 Shot-blasting

**IMPORTANT!**

**Failure to follow the instructions below could compromise safety and/or reduce the life of the disc brake and its components.**

If the vehicle is shot blasted, all rubber parts and pads on the disc brake must be protected. The brake chamber must be fitted (or any protective parts that have a similar sealing function). The shipping seal fitted to the brake chamber opening on a new disc brake does not provide adequate protection during shot-blasting.

**NOTE!**

**Do not forget to follow the recommendations of the brake chamber manufacturer.**

The disc brake must be thoroughly cleaned after blasting to ensure that its natural movement is not obstructed by remnants of shot-blasting material. Check seals and rubber parts to make sure they have not been damaged. Also refer to the axle manufacturer's instructions.

## 3 Initial and Final Procedures

### 3.1 General Information

The objective of this chapter is to give guidelines on how Initial and Final Procedures shall be performed in a standardised way.

**Initial Procedure** is a recurring procedure that have to be performed **prior** to the Inspection and/or Replacement procedures covered in this Service Manual.

**Final Procedure** is a recurring procedure that have to be performed **after** an Inspection and/or Replacement procedure covered in this Service Manual.

### 3.2 Initial Procedure

#### 3.2.1 Lift up and support the vehicle axle



**At least one of the vehicle's axles shall be chocked to prevent involuntary movement of the vehicle!**



**The vehicle manufacturer's safety precautions shall be followed when working on the vehicle!**



**Local safety precautions shall be complied!**

1. On a flat and even surface, block the wheels, see figure 5.
2. Lift the axles and place on stands.

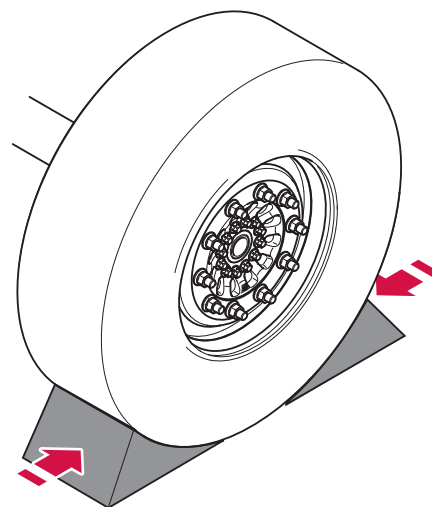

ModulT\_004

Figure 5. Block the wheels



If the disc brake is equipped with a parking brake function, ensure that the brake system is depressurised, that the spring brake chamber is fully disengaged and mechanically secured in the released position. See the vehicle manufacturer's instructions.

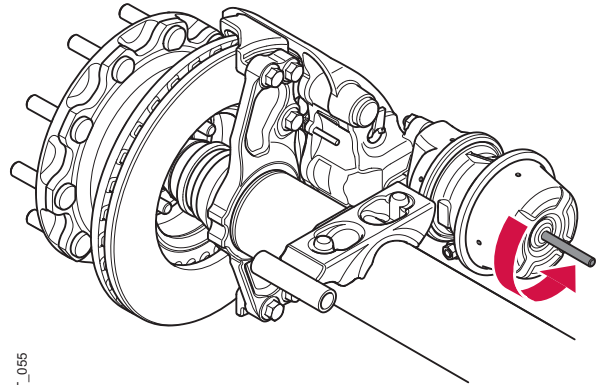

ModulIT\_065

Figure 6. Mechanically secure in the released position

3. Release the parking brake.

### 3.2.2 Removing the wheel



**Take all necessary safety precautions before wheel removal!  
The vehicle manufacturer's safety precautions shall also be followed!**

1. Check the free rolling resistance, if the resistance is higher than expected, tap the tyre to remove any normal rest tension. If the wheel still does not rotate freely then consult chapter "8. Fault Finding" to assist further.
2. Remove the wheel nuts followed by the wheel, see figure 7.

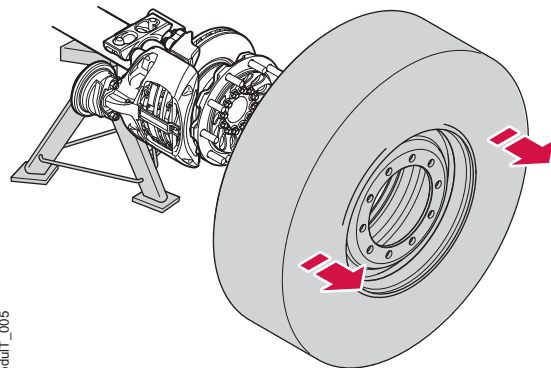

ModulIT\_005

Figure 7. Remove the wheel

## 3.3 Function Test

### 3.3.1 Check of Adjustment Unit

The function test can be carried out with the wheel both fitted or removed.

1. Check that the wheel/hub can rotate freely.  
If it does not then first tap to remove any rest tension. If the wheel still does not rotate freely then consult chapter "8. Fault Finding" to assist further.
2. Remove the reset shaft protection plug (A), see figure 8.

**IMPORTANT!**  
Use recommended tools only!

**NOTE!**  
The Torx 55 and the Thrust plate must be allowed to move unhindered!

**IMPORTANT!**  
Never use an impact wrench or similar to turn the reset shaft. This may damage internal parts of the mechanism! Torque is 20 Nm max.

3. Using Haldex special tool P/N95232 (Torx 55), de-adjust the brake by turning the reset shaft anti-clockwise by 4 clicks, or till the end stop, see (B) figure 8. A distinct clicking sound shall be heard and felt when de-adjusting.

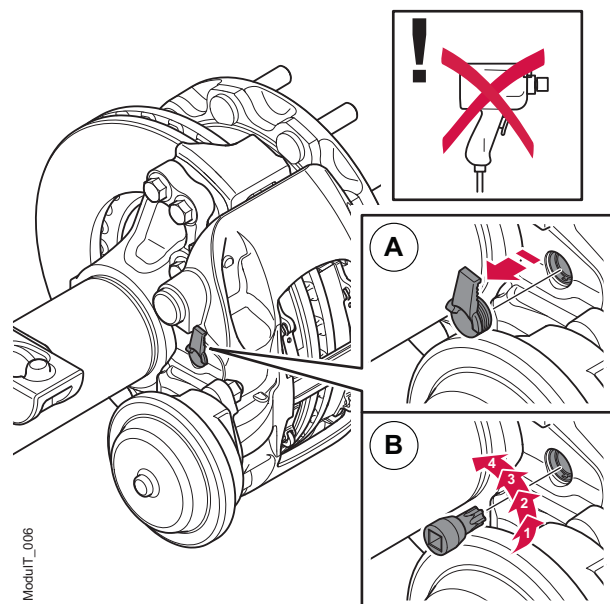

Figure 8. De-adjustment via the reset shaft

**IMPORTANT!**

**When reaching the end stop position of de-adjustment, never tighten and leave. Leaving the reset shaft tightened in the de-adjust position could stop the adjustment function from working!**

**After reaching the end stop position always then adjust by turning the reset shaft clockwise 90 degrees, thus activating the adjustment function.**

4. Leave the Torx 55 in position in the reset shaft.
5. Actuate the brakes 5 times by pressing and releasing the vehicles brake pedal through its full stroke. See figure 9. If no brake chamber is fitted then actuate the brake chamber lever manually with a suitable tool.
6. The Torx 55 must rotate clockwise only on each actuation, showing that the automatic adjustment function is working.
7. If the Torx 55 rotates back and forth or not at all, then the adjustment function is not working correctly.
8. To check further, manually adjust the reset shaft by turning the Torx 55 clockwise by 360 degrees, and then anti-clockwise by 180 degrees to ensure the adjuster is not jammed at the full de-adjust position.
9. Also note that once the excessive clearance is taken up by the adjuster the Torx 55 will naturally stop rotating. If in doubt, turn the Torx 55 anti-clockwise by 180 degrees and then press the brake pedal again to check.
10. If the Torx 55 still rotates back and forth during actuation then the adjustment function is defective and the calliper must be replaced.

See chapter "5.7 Replacement of Disc Brake".

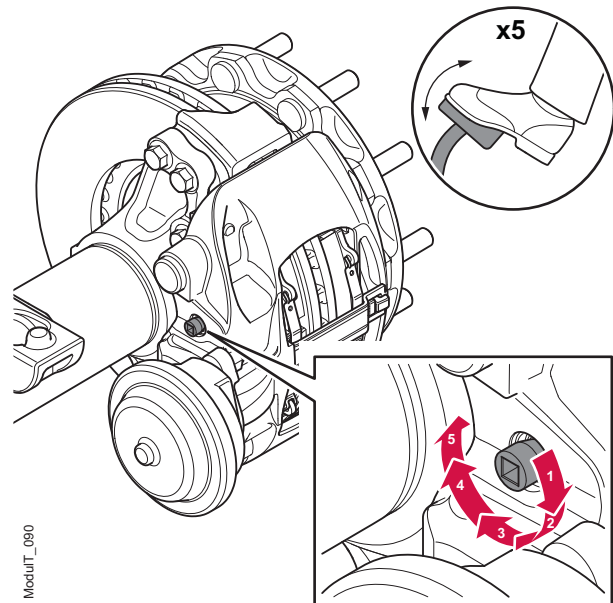

Figure 9. Brake actuation

## 3.4 Final Procedure

1. Using Haldex special tool P/N95232 (Torx 55), manually adjust the brake by turning the reset shaft clockwise until the pads touch the disc and you feel an end stop.
2. Then turn the reset shaft anti-clockwise by 2 clicks, see figure 9.1.

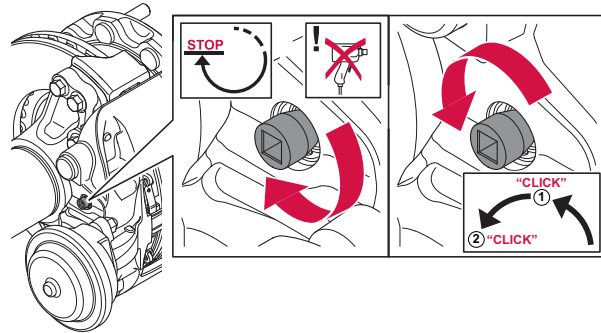

Figure 9.1. Initial brake pad setting

This procedure is the initial brake pad setting.

3. Fit the reset shaft protective plug into the calliper, ensure it is correctly orientated and pushed fully into its correct sealing position. Failure to do so may compromise the life of the brake!

See Figure 10.

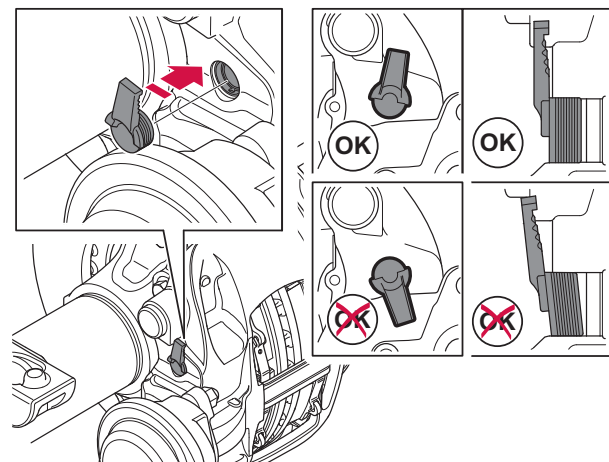

Figure 10. Correct fitment of the protective plug

### 3.4.1 Mounting of the wheel



**Make sure that the brake hoses are in good condition, that they are layed/ducted and fastened correctly.**

1. Check the free rolling resistance. The disc brake must not be obstructed in any way.
2. Mount the wheel, see Figure 11.

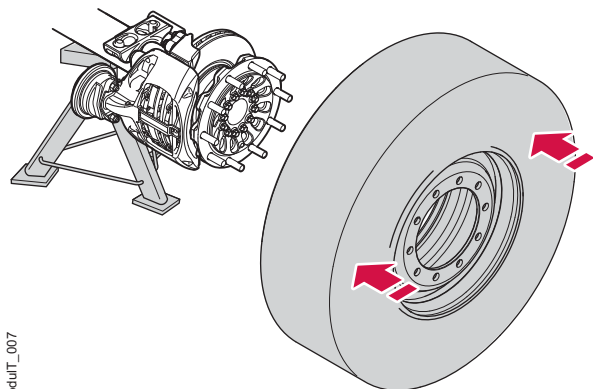

ModulIT\_007

Figure 11. Mount the wheel

### 3.4.2 Lowering of the vehicle axle



If the disc brake is equipped with a parking brake function, ensure that the brake system is pressurised, that the spring brake chamber is fully engaged and mechanically secured in the active position. See the vehicle manufacturer's instructions.

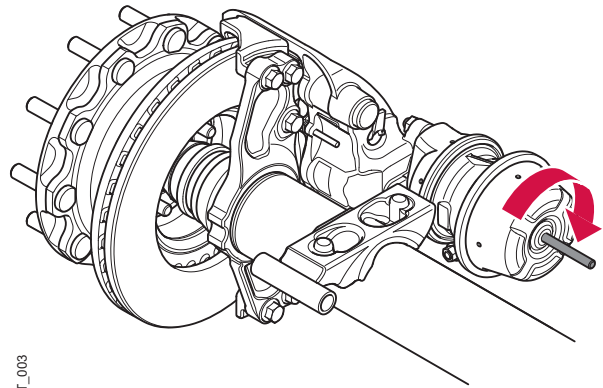

ModuT\_003

Figure 12. Mechanically secure in the active position

#### **IMPORTANT!**

**Apply air to the parking brake. Make sure that there is sufficient air in the system (min. 6 bar).**

1. Activate the parking brake if fitted with a spring brake chamber.
2. Lift the axles so that the stands can be removed.
3. Carefully lower the vehicle to the ground.
4. Remove the wheel blocks, see Figure 13.

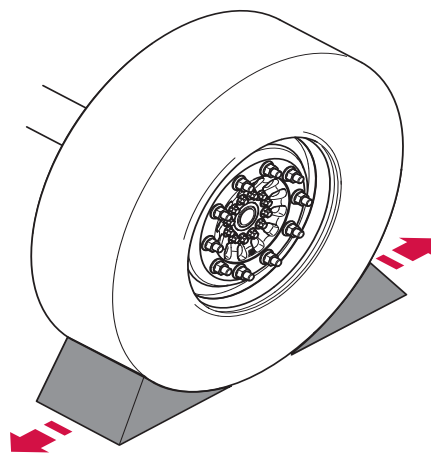

ModuT\_056

Figure 13. Remove the stops

#### **IMPORTANT!**

**After carrying out any work, always finish with a general checking operation followed by test drive to ensure that the brakes are working correctly!**



## 4 Inspection Procedures

### 4.1 General Information

The objective of this chapter is to give guidance on how inspection of the brake components shall be conducted. Always start by consulting the Inspection interval table below in chapter 4.2.

The Inspection interval table displays how frequent the different brake components shall be inspected and on which pages the check instructions are found.

The majority of the inspections demand that the wheel is removed from the vehicle. Before removing the wheel read chapter "2. Safety Precautions" followed by "3. Initial and Final Procedures".

### 4.2 Inspection intervals

The check intervals specified in the table below are maximum intervals. Depending on the vehicle application, type of driving, adjustment to the vehicle manufacturer's service/inspection intervals etc, there may be a need for more frequent inspections.

- C = Check
- A = Inspection
- \* = With wheels fitted
- \*\* = With wheels removed

	Before starting to use vehicle	Daily	After 3000-5000 km.	Every 3 month	Every 12 month	If parts are replaced in operating system.	See Page
Adjustment of Control System/Valves	C/A*				C*	C/A*	7
Braking Force Distribution - Tractor/Trailer			C/A*		C*	C/A*	7
Function Test				C*	C**		12
Safety Check		C*			C**		17
Brake Pads				I*	I**		18
Brake Disc				I*	I**		20
Plugs and Protective Cups					I**		21
Thrust Plate Guide Pins					I**		22
Actuation Interface					I**		23
Slide Pin Bellows					I**		26
Adjustment Screw Bellows					I**		27
Slide Function					I**		29

## 4.3 Inspections

### 4.3.1 Daily Safety Check



**Contact the Service Workshop immediately if there is any sign of reduced performance or the brakes do not work properly!**

1. Check that the brakes function properly before driving and that they work effectively and smoothly.
2. Check that the service and parking brake function is effective by trying to drive the vehicle with the service and parking brake applied.

### 4.3.2 Check overall condition

1. Make sure you have good lighting conditions.
2. Inspect visible parts of the brake and its components. Look for:
  - Damage
  - Collection of debris
  - Corrosion
  - Overheating signs
  - Cracks in brake discs
  - Unusual wear etc

### 4.3.3 Check Brake Pad wear



**Wear respiratory protection in order to avoid inhaling particles which can be hazardous to your health! Brake pad wear produce dust which can cause lung damage!**

#### NOTE!

**Step 1 in this procedure only indicate the pad wear of the outer pad! For a full examination do all steps.**

1. Inspect the position of the Visual Wear Indicator (VWI), as located and shown in figure 14. This check can be done with either the wheel fitted or removed.

The VWI provides an indication of pad wear condition, it does not provide an accurate measurement of pad wear on both pads.

To obtain an accurate wear measurement of both pads continue with the instructions which follow.

2. Remove the wheel following chapter "3.2 Initial Procedure".
3. Remove brake pads according to chapter "5.2.2 Remove Brake Pads".
4. Look for unusual conditions like excessive corrosion and high heat cycles i.e. delamination, discolouration, etc. If found refer to chapter "8 Fault Finding" for actions.
5. On both brake pads measure the distance from back plate (A) to wear surface (B) of the brake pad in four places, see figure 15. Minimum permitted lining thickness (friction material) is 2 mm.
6. Check the condition of the back plate (A).
7. Replace brake pads if they are worn out or if they are expected to be so before the next inspection.

For replacement follow the instructions in chapter "5.2 Replacement of Brake Pads".

8. If the inspection is completed satisfactorily, conclude by following chapters "5.2.3 Install Brake Pads" and "5.2.4 Final Procedure".

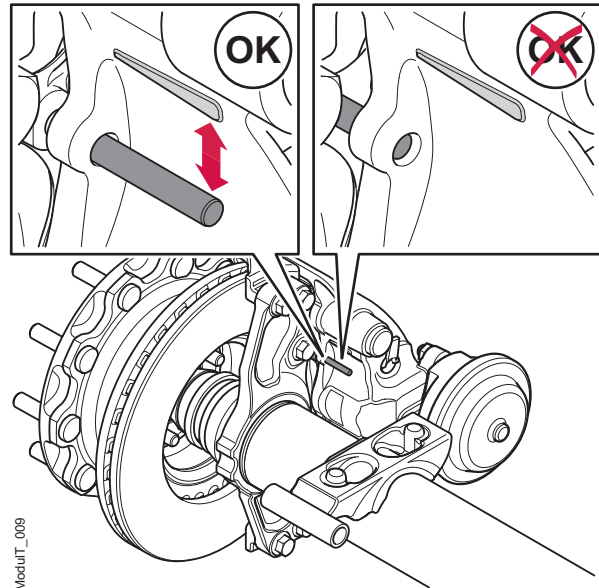

Figure 14. Inspection of the Visual Wear Indicator

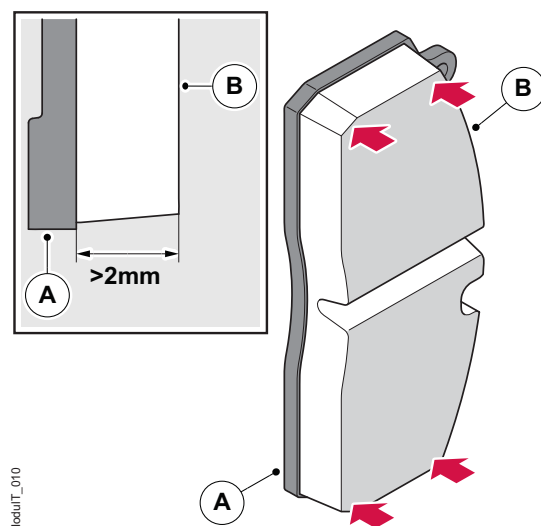

Figure 15. Measuring the pad wear condition

#### NOTE!

**This brake disc inspection check procedure is only a general guide, refer to the vehicle manufacturers documentation for specific brake disc information and instruction.**

### 4.3.4 General Brake Pad clearance check



**Wear respiratory protection in order to avoid inhaling particles which can be hazardous to your health! Brake pad wear produce dust which can cause lung damage!**

Checking the clearance is only required for an approximation of the clearance between the brake disc and the brake pads.

The check can be carried out with or without the brake chamber fitted.

This check is best performed after the wheel is removed and before the brake is de-adjusted. For this situation the steps 2 and 3 below can be skipped.

1. Read and follow chapters "3.2 Initial Procedure" and paragraph 4 from "5.2.2 Remove Brake Pads" prior to checking the pad clearance.
2. Adjust the reset shaft by inserting and manually turning the Haldex special tool P/N 95232 (Torx 55) clockwise until it comes to a stop and any excessive clearance is removed. Then de-adjust the reset shaft by turning it anti-clockwise by 2 clicks.
3. Activate the brake until the Torx 55 male no longer rotates because any excessive clearance has been removed by the adjustment function.
4. Insert two feeler gauges in between the calliper and the outer brake pad to measure the clearance. Position the feeler gauges in the upper and lower part of the brake pad back plate so an average clearance is measured, see figure 16.
5. The normal running clearance is between 0,7mm and 1,1mm. If the measurement is outside of the normal running condition then refer to chapter "8. Fault Finding" for further investigations.
6. Once the inspection is completed satisfactorily, conclude by reading and following chapters, paragraph 6 from "5.2.3 Install Brake Pads" and all from "5.2.4 Final Procedure".

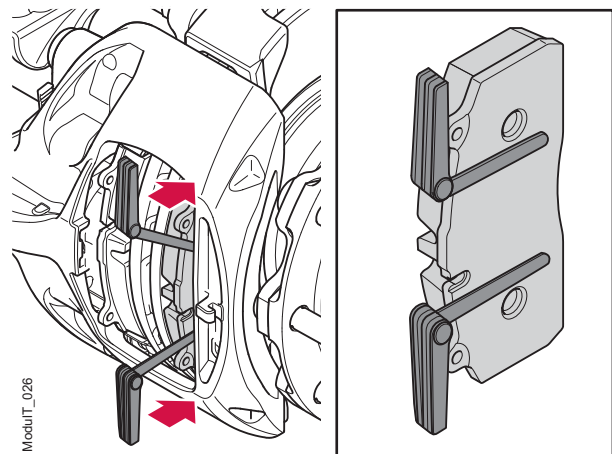

Figure 16. Correct location of the feeler gauges

### 4.3.5 Check Brake Disc



**Wear respiratory protection in order to avoid inhaling particles which can be hazardous to your health! Brake pad wear produce dust which can cause lung damage!**

1. Look for wear, damages and cracks, see figure 17. Also refer to the axle/vehicle manufacturer instructions.

Cracks that enter the cooling ducts via the outer radius are not permitted!

Acceptable crack length	Unacceptable crack length
< 75% of brake disc width	> 75% of brake disc width

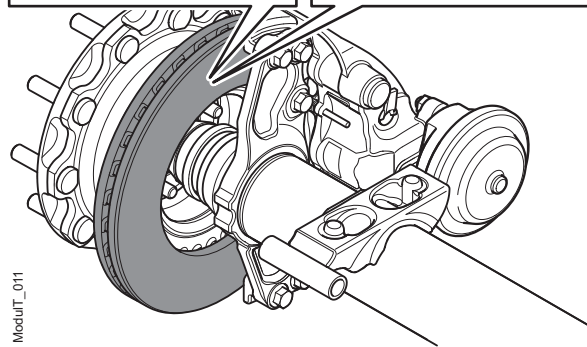
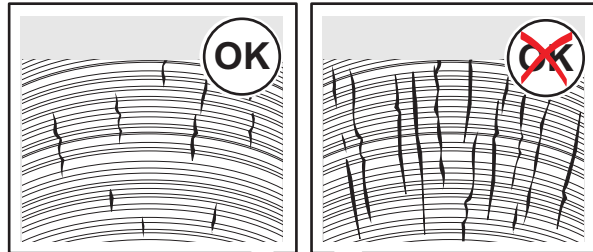

Figure 17. Inspection of the Brake Disc

2. Measure the thickness of the brake disc using a slide calliper. If the brake disc has a wear ridge, the measurement can be performed using two spacers (B) (e.g. 5 mm thick flat washers), see figure 18. Reduce the measured dimension by the total thickness of the two spacers (B).

Minimum thickness of the brake disc is 37 mm.

The brake disc must be replaced if the wear limits have been exceeded.

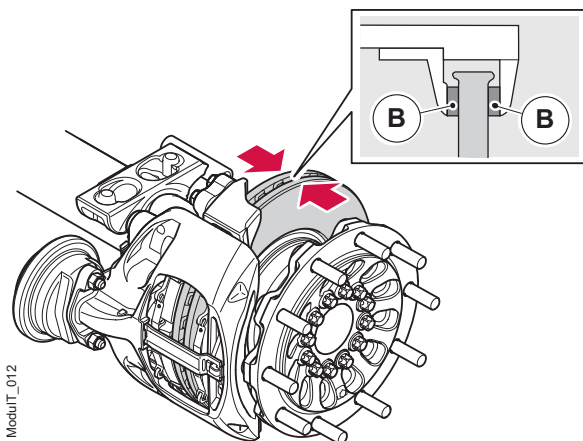

Figure 18. Measuring the Brake Disc thickness

**NOTE!**

**This brake disc inspection check procedure is only a general guide, refer to the vehicle manufacturers documentation for specific brake disc information and instruction.**

### 4.3.6 Check Plugs and Protective Cups



**Wear respiratory protection in order to avoid inhaling particles which can be hazardous to your health! Brake pad wear produce dust which can cause lung damage!**

**IMPORTANT!**

**Use a vacuum cleaner to clean surfaces. Do not use compressed air!**

**IMPORTANT!**

**Failure to follow the instructions below could compromise safety and/or reduce the life of the Disc Brake and its components.**

1. Read and follow chapter "3.2 Initial Procedure" prior to inspecting the protective plugs and cups.
2. Remove dirt from surfaces if necessary.
3. Check for signs of excessive heat exposure, discolouration, debris etc.
4. The following plugs and protective cups shall be in place and intact:

The reset shaft protection plug identified as (A) and calliper seal (B), see figure 19.

Protection plug B is never removed.

5. The three protection cups; two for slide pin protection (C) and one for the mechanism (D), see figure 20.

Protection cup D is never removed.

6. Once the inspection is completed satisfactorily, conclude by reading and following chapter "3.4 Final Procedure".

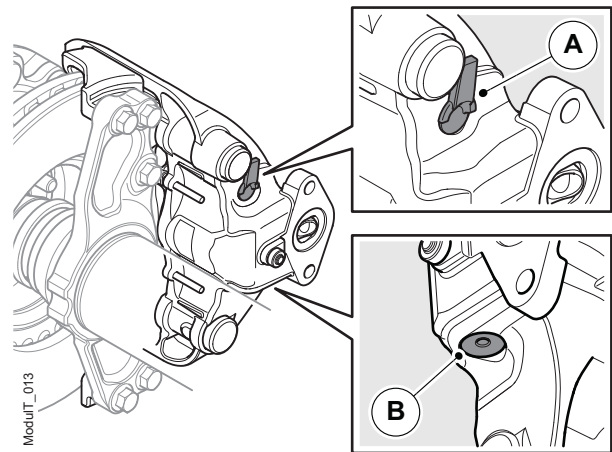

Figure 19. The two protection plugs

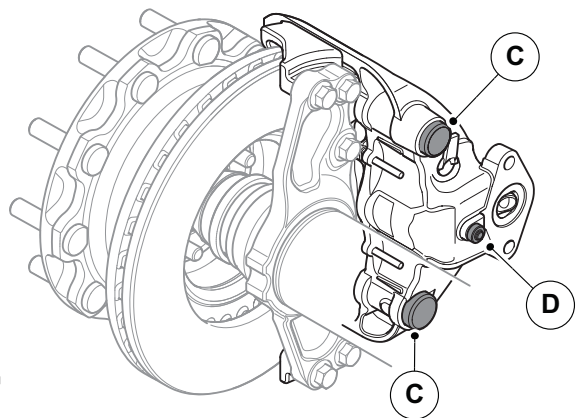

Figure 20. The three protection cups

**IMPORTANT!**

**Never remove the protection plug (B) and protection cup (D) on figures 20 and 21. If the protection plug (B) is removed it will void warranty and will compromise the life of the disc brake!**

### 4.3.7 Check Thrust Plate Guide Pins



**Wear respiratory protection in order to avoid inhaling particles which can be hazardous to your health! Brake pad wear produce dust which can cause lung damage!**

**IMPORTANT!**

**Use a vacuum cleaner to clean surfaces. Do not use compressed air!**

1. Read and follow chapter "3.2 Initial Procedure" prior to inspecting the thrust plate guide pins.
2. Remove dirt from surfaces as necessary.
3. Check that the two thrust plate guide pins (E), see figure 21, are in their correct position.
4. Check that the thrust plate with guide pins are free to move without obstruction.
5. Once the inspection is completed satisfactorily, conclude by reading and following chapter "3.4 Final Procedure".

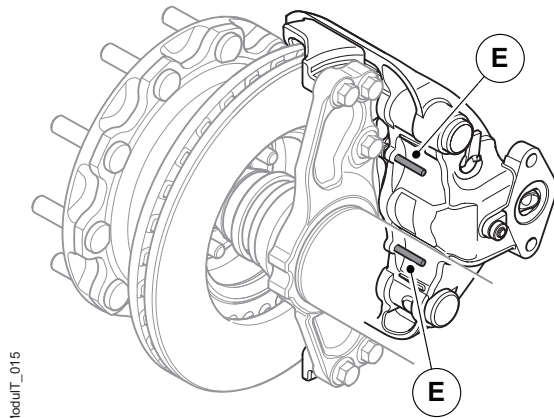

Figure 21. The two thrust plate guide pins

### 4.3.8 Check Actuation Interface



**Wear respiratory protection in order to avoid inhaling particles which can be hazardous to your health! Brake pad wear produce dust which can cause lung damage!**

**IMPORTANT!**

**It is important to take care when using chemicals and/or cleaning tools (e.g. knife, brush etc). This to avoid damage or displacement of hoses, seals and other components.**

**IMPORTANT!**

**Use a vacuum cleaner to clean surfaces. Do not use compressed air**

This inspection procedure covers both types of brake chamber; normal (service) and spring brake (parking) chambers.

1. Read and follow chapter "3.2 Initial Procedure" prior to inspecting the actuation interface.
2. Thoroughly clean around the mating surfaces of the brake chamber (A) and calliper (B) to ensure that dirt does not get into the mechanism area when removing the brake chamber. See figure 22.

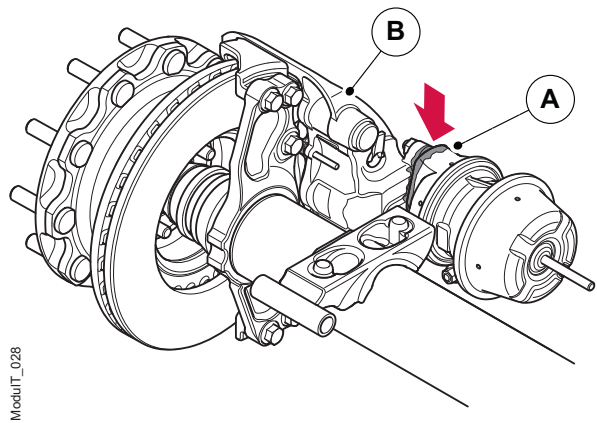

ModuIT\_028

Figure 22. The mating surfaces of the brake chamber and calliper



**If the disc brake is equipped with a parking brake function, ensure that the brake system is depressurised, that the spring brake chamber is fully disengaged and mechanically secured in the released position. See the vehicle manufacturer's instructions.**

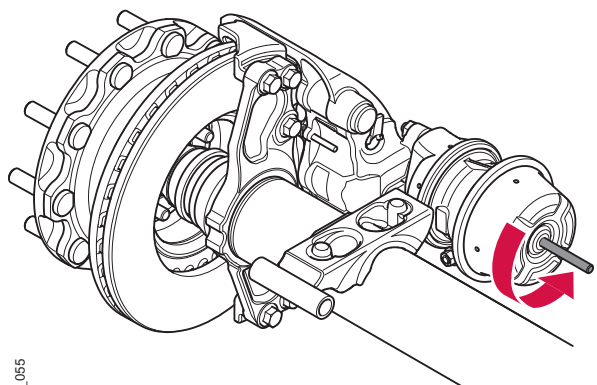

ModuIT\_065

Figure 6. Mechanically secure in the released position





**Pressure from lines and components shall be released before opening them!**

3. If applicable ensure that the spring brake chamber (F) is fully disengaged and mechanically secured in the released position.
4. Ensure that the brake chamber is depressurised.
5. Remove the two nuts (E) holding the brake chamber from the calliper (B), see figure 23.

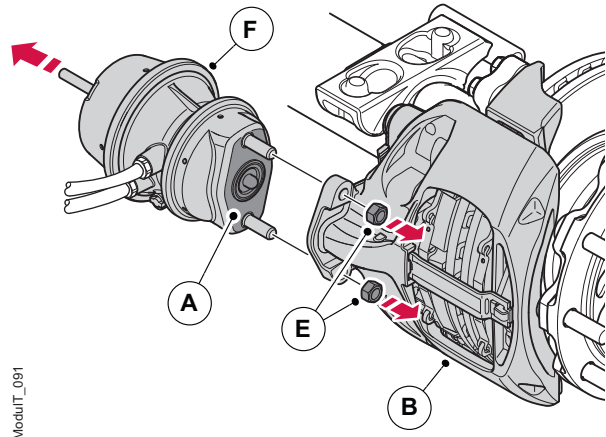

Figure 23. Removal of brake chamber items

6. With the brake chamber removed and secured, the brake chamber actuation rod should protrude ~15 mm in its rest position, See figure 24.
7. Activate the service brake, the brake chamber actuation rod should protrude ~80 mm.
8. Also check that the actuation rod extends perpendicular to the external seal flange.

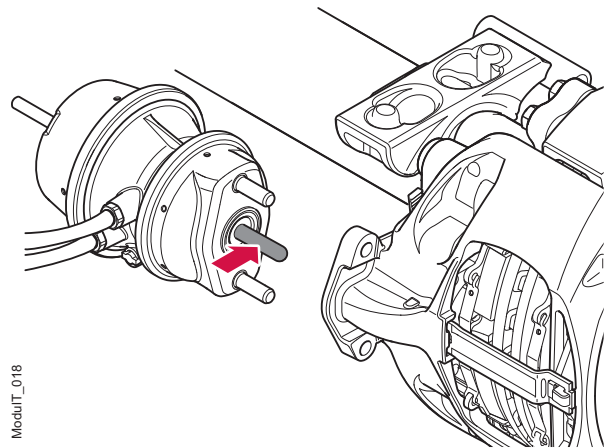

Figure 24. The actuation rod

9. Check through the aperture in the brake chamber attachment flange for moisture/corrosion, see figure 25. It's important to look inside the aperture and not just on the surface.

If corrosion is seen then further inspection is necessary. If concluded that water has ingressed causing internal corrosion/damages to the mechanism then replace the calliper complete to avoid operating problems.

If action is required see chapter "5.8 Replacement of Calliper".

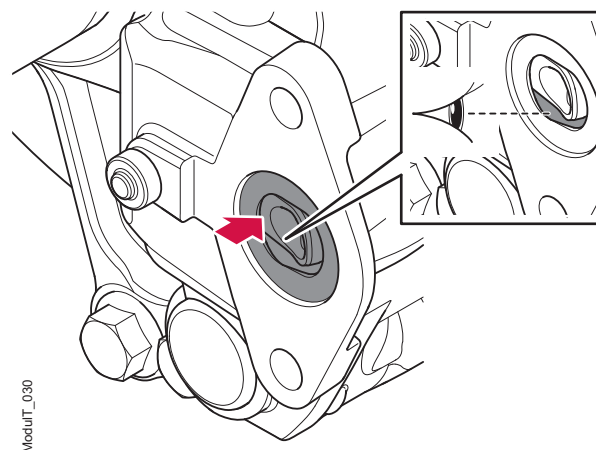
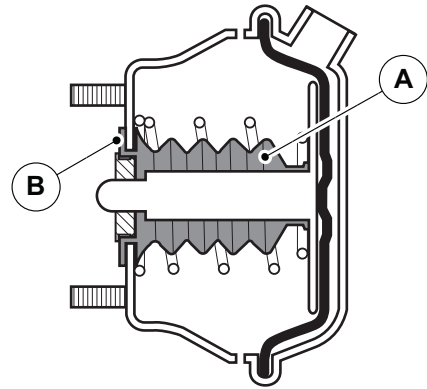

Figure 25. The brake chamber aperture

10. On the brake chamber, there must be an internal bellows (A) on the push rod, see figure 26.
11. Check that the bellows are complete and not damaged by looking around and down the push rod shaft. Also look for signs of water or corrosion which may be a sign that the bellows are damaged.
12. Check that the external seal flange (B) is correctly seated in place, intact and undamaged.
13. Once the inspection is completed satisfactorily, conclude by reading and following chapters "5.3.3 Install Brake Chamber" and "5.3.4 Final Procedure".



ModulIT\_031

Figure 26. Internal view of a brake chamber

### 4.3.9 Check Slide Pin Bellows



**Wear respiratory protection in order to avoid inhaling particles which can be hazardous to your health! Brake pad wear produce dust which can cause lung damage!**

**IMPORTANT!**

**It is important to take care when using chemicals and/or cleaning tools (e.g. knife, brush etc). This to avoid damage or displacement of hoses, seals and other components.**

**IMPORTANT!**

**Use a vacuum cleaner to clean surfaces. Do not use compressed air**

1. Read and follow chapters "3.2 Initial Procedure" and "5.2.2 Remove Brake Pads" prior to inspecting the slide pin bellows.
2. Inspect the Leading slide pin bellows (A) and the Trailing slide pin bellows (B), see figure 27. Look all around the bellows for damage signs than could have been caused by debris, stones or overheating.

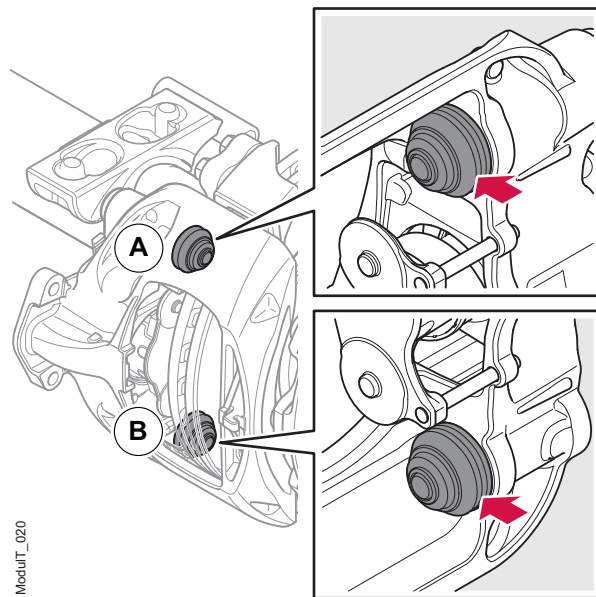

ModuIT\_020

Figure 27. Inspecting the slide pin bellows

3. If the bellows are damaged then they need replacing. For instructions on how to replace the bellows read and follow "5.5 Replacement of Slide Function Assembly".
4. Once the inspection is completed satisfactorily, conclude by reading and following chapters "5.2.3 Install Brake Pads" and "5.2.4 Final Procedure".

### 4.3.10 Check Adjustment Screw Bellows



**Wear respiratory protection in order to avoid inhaling particles which can be hazardous to your health! Brake pad wear produce dust which can cause lung damage!**

**IMPORTANT!**

**It is important to take care when using chemicals and/or cleaning tools (e.g. knife, brush etc). This to avoid damage or displacement of hoses, seals and other components.**

**IMPORTANT!**

**Use a vacuum cleaner to clean surfaces. Do not use compressed air!**

1. Read and follow chapters "3.2 Initial Procedure" and "5.2.2 Remove Brake Pads", prior to checking the adjustment screw bellows.

**IMPORTANT!**

**Never use an impact wrench or suchlike to turn the reset shaft. This may damage the disc brakes mechanism! Torque is 20 Nm max.**

**Note!**

**Do not over adjust/extend the thrust plate whilst carrying out the inspection. Over adjustment/extension will cause the thrust plate to disengage from the adjustment screw and if done unintentionally may cause damage to the thrust plate bellows! Max distance between the calliper and thrust plate is 60 mm.**

2. Using Haldex special tool P/N95232 (Torx 55), manually turn the reset shaft clockwise to adjust the brake so that the thrust plate (A) is extended and the bellows can be viewed. Stop when the distance between the inner pad face of the thrust plate and outer pad face on the calliper is 60 mm, see figure 28.

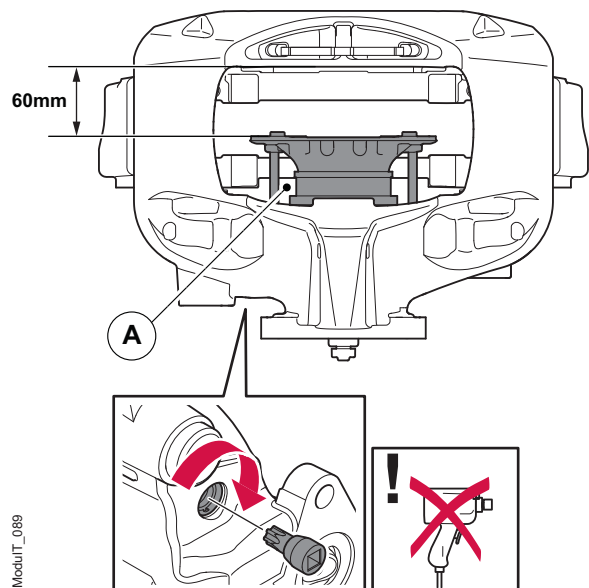

Figure 28. Max extension to check the thrust plate bellows

3. Inspect the adjustment screw bellows, see figure 29. Look all around the bellows for damage signs that could have been caused by debris, stones or overheating.
4. If the bellows are damaged then it needs replacing. For instructions on how to replace the bellows read and follow "5.4 Replacement of Adjustment Screw Bellows".
5. If OK then manually de-adjust the thrust plate by turning the Torx 55/reset shaft anti-clockwise, until the position required to refit the brake pads.
6. Once the inspection is completed satisfactorily, conclude by reading and following chapters "5.2.3 Install Brake Pads" and "5.2.4 Final Procedure".

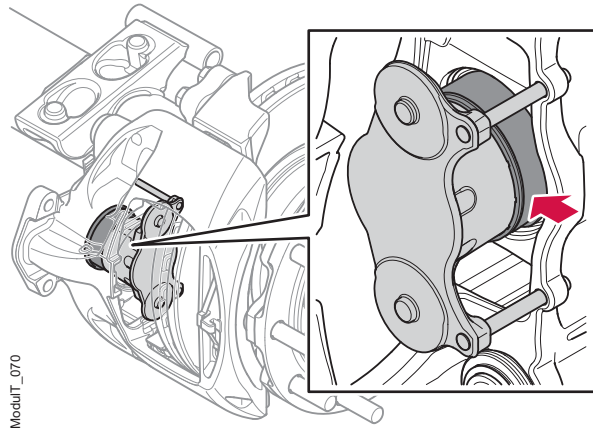

Figure 29. Inspect the adjustment screw bellows

### 4.3.11 Check Slide Function



**Wear respiratory protection in order to avoid inhaling particles which can be hazardous to your health! Brake pad wear produce dust which can cause lung damage!**

**IMPORTANT!**

**It is important to take care when using chemicals and/or cleaning tools (e.g. knife, brush etc). This to avoid damage or displacement of hoses, seals and other components.**

**IMPORTANT!**

**Use a vacuum cleaner to clean surfaces. Do not use compressed air!**

1. Read and follow chapters "3.2 Initial Procedure" and "5.2.2 Remove Brake Pads" prior to inspecting the slide function.
2. Once the brake pads are removed, move the calliper by hand back and forth to check its movement, see figure 30. The calliper must be free to slide on the leading and trailing slide pins.
3. If the movement is felt to be obstructed in some way then it is necessary to determine the root cause, see chapter "8. Fault Finding" for assistance in this.
4. If the root cause investigation concludes that the slide function needs replacing then follow chapter "5.5 Replacement of Slide Function Assembly".
5. Once the inspection is completed satisfactorily, conclude by reading and following chapters "5.2.3 Install Brake Pads" and "5.2.4 Final Procedure".

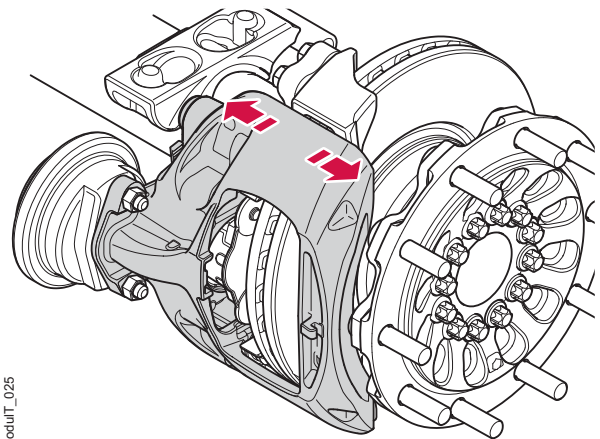

Figure 30. Calliper free movement

**IMPORTANT!**

**Obstruction of the slide function can cause operational problems like hot brakes and uneven brake pad wear.**

# 5 Replacement Procedures

## 5.1 General Information

The objective of this chapter is to give instruction and guidance on how the disc brake and/or its components shall be replaced. All the replacement procedures in this chapter require that the wheel is taken off to enable the replacement work to be carried out.

## 5.2 Replacement of Brake Pads

### 5.2.1 Initial Procedure

Read and follow chapter "3.2 Initial Procedure" prior to removing the brake pads.

### 5.2.2 Remove Brake Pads



**Wear respiratory protection in order to avoid inhaling particles which can be hazardous to your health! Brake pad wear produce dust which can cause lung damage!**

**IMPORTANT!**

**Use a vacuum cleaner to clean surfaces. Do not use compressed air!**

**IMPORTANT!**

**It is important to take care when using chemicals and/or cleaning tools (e.g. knife, brush etc). This to avoid damage or displacement of hoses, seals and other components**

1. If necessary remove dirt, dust and other possible obstruction.

**NOTE!**

The thrust plate must be fully retracted to be able to fit new pads.

**IMPORTANT!**

Only use Haldex special tools where specified!

**IMPORTANT!**

Never use an impact wrench or suchlike to turn the reset shaft. This will damage internal parts of the mechanism! Torque is 20 Nm max.

2. Remove the reset shaft protection plug. See figure 31.
3. Using Haldex special tool P/N 95232 (Torx 55), manually turn the reset shaft anti-clockwise to de-adjust the brake so that the thrust plate fully retracts to its inner position.

A clicking sound shall be heard and felt when de-adjusting.

The stop at fully retracted inner thrust plate position must be distinct, but do not exceed 20 Nm in torque or leave it tightened in this position.

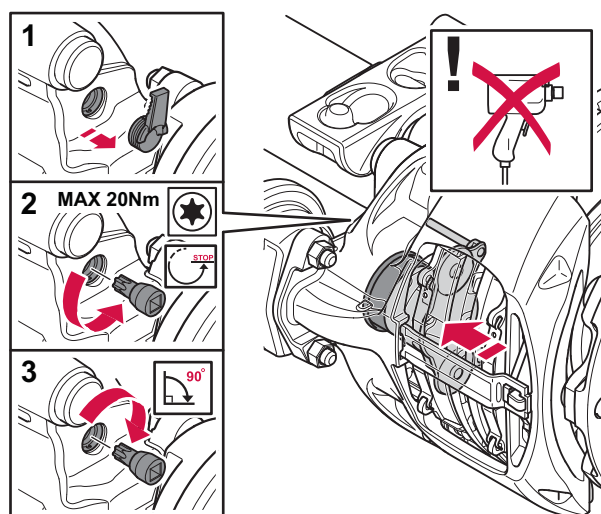

Figure 31. De-adjust the thrust plate via the reset shaft



**Sudden release of tensioned springs can cause injury!**



**Do not actuate the brake when changing the brake pads!**

**Also, ensure the air brake system is pressurised during the replacement procedure, minimum 4bar! If the pressure drops below 4bar the park brake will be acutated.**



**IMPORTANT!**

**Always ensure the pad retainer spring bracket is fully held down whilst levering out the pad retainer**

4. Remove the pad retainer by first pushing and holding down the spring bracket (A), see figure 32. Whilst the spring bracket (A) is held down, slide out and remove the pad retainer (B). A tool can be used to help slide out the pad retainer if unable to do so be hand. Continue to remove the two pad springs (C).

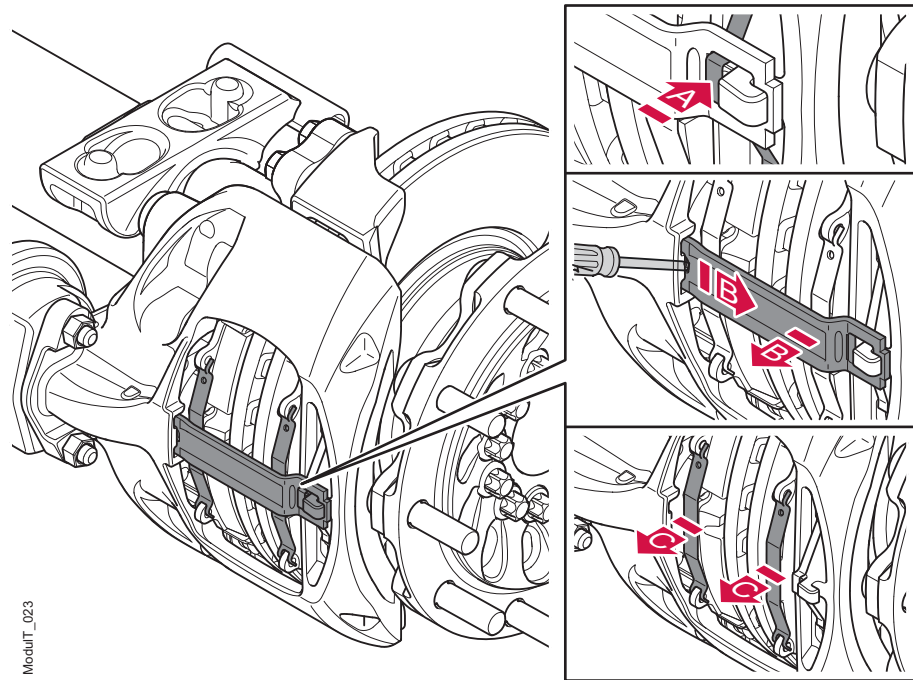

Figure 32. Removal of brake pad components

**NOTE!**

**Always remove the outer brake pad first.**

**IMPORTANT!**

**Always remove the outer brake pad first! You cannot directly pull out the inner brake pad with the outer still in place as the inner brake pad is located to the thrust plate on two points.**

5. Remove the brake pads; always remove the outer brake pad (A) first, followed by the inner brake pad (B). See figure 33.

This is because the inner brake pad back plate locates on two holes which mate to the thrust plate, therefore you cannot directly pull out the inner brake pad with the outer brake pad still being in place.

Once the outer brake pad is removed the calliper can be slid across to allow for the inner brake pad to be removed.

6. Remove the pad retainer spring bracket (C).

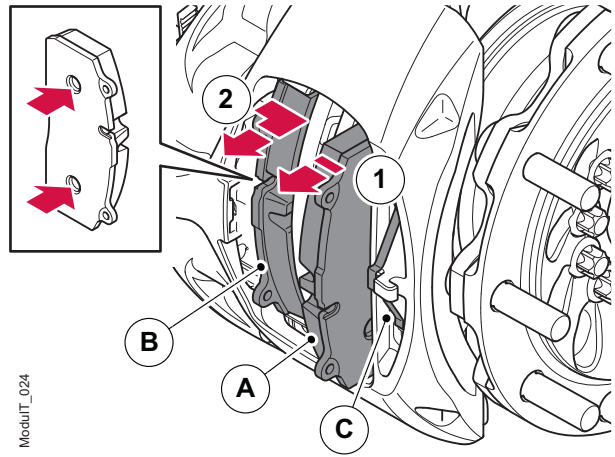

Figure 33. Removal of brake pads

### 5.2.3 Install Brake Pads

1. Make sure that the brake is fully de-adjusted before fitting new brake pads.
2. Check that the contact surfaces on the carrier, calliper and thrust plate are free from dirt and corrosion. Clean if necessary.

**IMPORTANT!**  
**The inner brake pad must always be installed first!**

**IMPORTANT!**  
**Ensure that the friction material faces the brake disc!**

3. First install the inner brake pad (B) in the carrier, note that the inner brake pad locates onto the thrust plate on two points, see figure 34. Then fit the outer brake pad (A).
4. Check that the contact surfaces on the pad retainer spring bracket are free from dirt and corrosion. Clean if necessary.
5. Install a new spring bracket (C) into the calliper and ensure it is seated in position correctly.

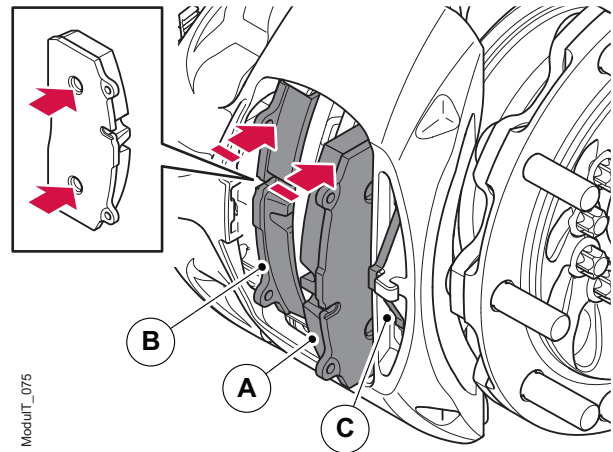

Figure 34. Install the brake pads



**Upon assembly, ensure the pad retainer spring bracket is in its correct locking position**

6. Fit the new pad springs (A) and the pad retainer (B).

The pad retainer is fitted by first locating the pad retainer in the housing end in the calliper aperture, then compressing the pad springs and locating the pad retainer slot over the calliper latch, finally slide the pad retainer under the calliper latch until the spring bracket pops into its locking position, see figure 35.

If necessary, use a tool to help push the pad retainer into position.

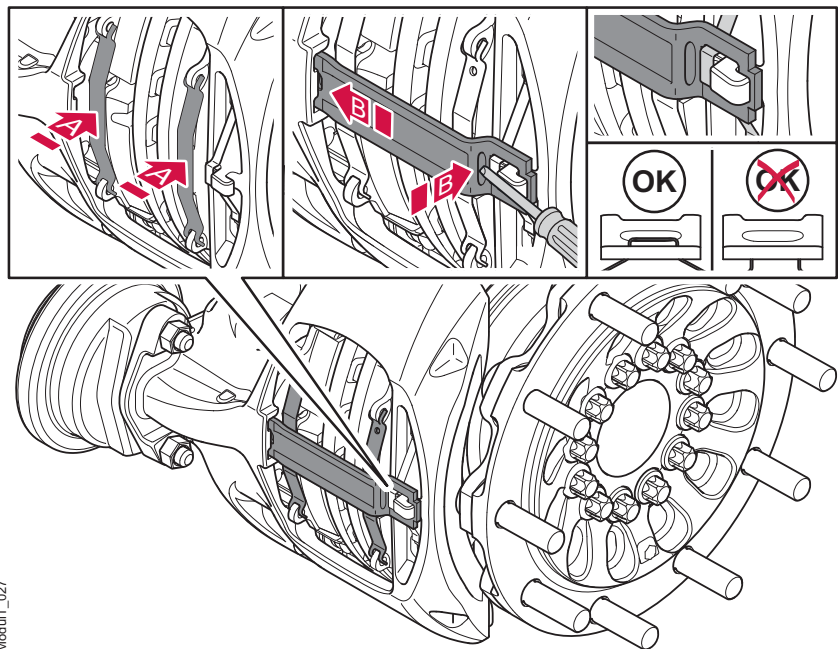

ModuIT\_027

Figure 35. Installation brake pad components

## 5.2.4 Final Procedure

To conclude this procedure read and follow chapters:

1. "3.3 Function Test" to ensure that the disc brake is working correctly;
2. "3.4 Final Procedure".

## 5.3 Replacement of Brake Chamber

### 5.3.1 Initial Procedure

Read and follow chapter "3.2 Initial Procedure" prior to removing the spring brake chamber.

### 5.3.2 Remove Brake Chamber



**Wear respiratory protection in order to avoid inhaling particles which can be hazardous to your health! Brake pad wear produce dust which can cause lung damage!**

#### **IMPORTANT!**

**Use a vacuum cleaner to clean surfaces. Do not use compressed air!**

#### **IMPORTANT!**

**It is important to take care when using chemicals and/or cleaning tools (e.g. knife, brush etc). This to avoid damage or displacement of hoses, seals and other components.**

1. Carefully clean around the mating surfaces of the brake chamber (A) and the calliper (B) to ensure that dirt does not get into the mechanism area when removing the brake chamber. See figure 36.

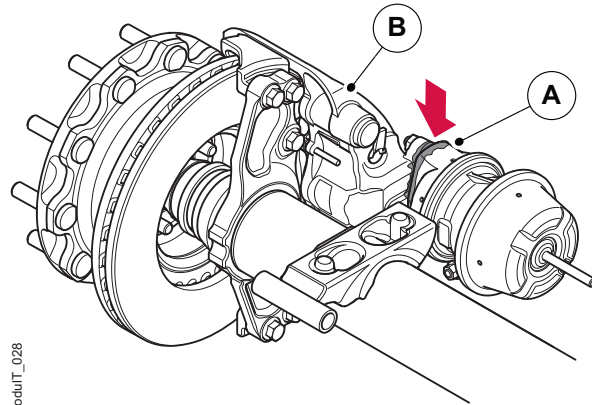

ModulT\_028

Figure 36. The mating surfaces of the brake chamber and calliper



If the disc brake is equipped with a parking brake function, ensure that the brake system is depressurised, that the spring brake chamber is fully disengaged and mechanically secured in the released position. See the vehicle manufacturer's instructions.

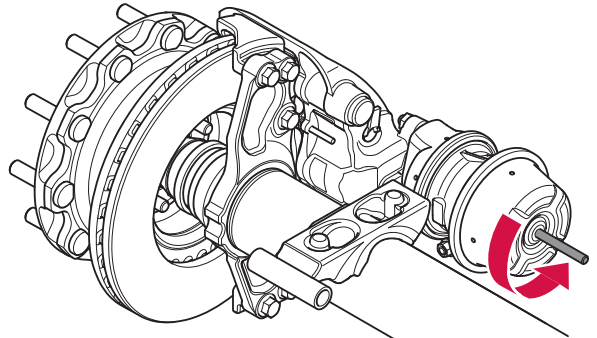

Figure 6. Mechanically secure in the released position



Pressure from lines and components shall be released before opening them!

2. If applicable ensure that the spring brake chamber (F) is fully disengaged and mechanically secured in the released position. See figure 37.
3. Ensure that the brake chamber (A) is depressurised.
4. Mark and remove the hose connections of the service brake (C) and if applicable the parking brake (D).
5. Remove the two nuts (E) holding the brake chamber. Remove the brake chamber (A) from the calliper (B).
6. Once the brake chamber is removed it is good practice and highly recommended to read and follow chapter "4.3.8 Check Actuation Interface".

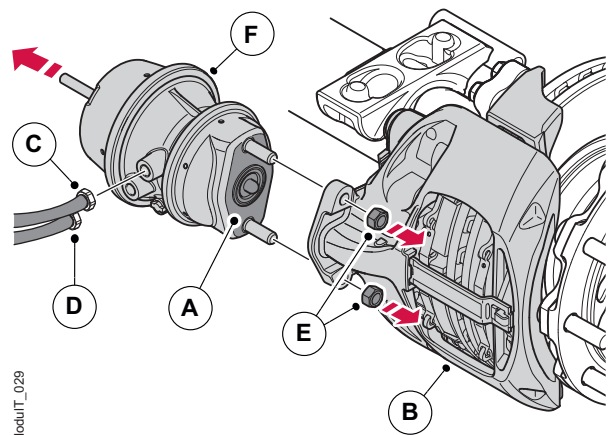

Figure 37. Removal of brake chamber items

### 5.3.3 Install Brake Chamber

1. Check that the brake chamber being installed is the correct one for the application and vehicle. If a spring brake chamber is being installed, ensure that the parking brake spring is caged in accordance with the manufacturer's instructions.
2. Prior to fitting the brake chamber it is good practice and highly recommended to read and follow chapter "4.3.8 Check Actuation Interface".

**IMPORTANT!**

**It is important to take care when using chemicals and/or cleaning tools (e.g. knife, brush, etc). This to avoid damage or displacement of hoses, seals and other components.**

3. Check that the surface of the calliper that mates with the brake chamber is free from dirt, moisture and corrosion. Do the same check on the brake chambers mating face (A) and seal. See figure 38.

Ensure the brake chamber seal is in the correct position and not damaged.

4. Put a knob of general purpose grease in the ball cup of the brake chamber lever. Do not overfill the cup or let grease fall inside the brake.

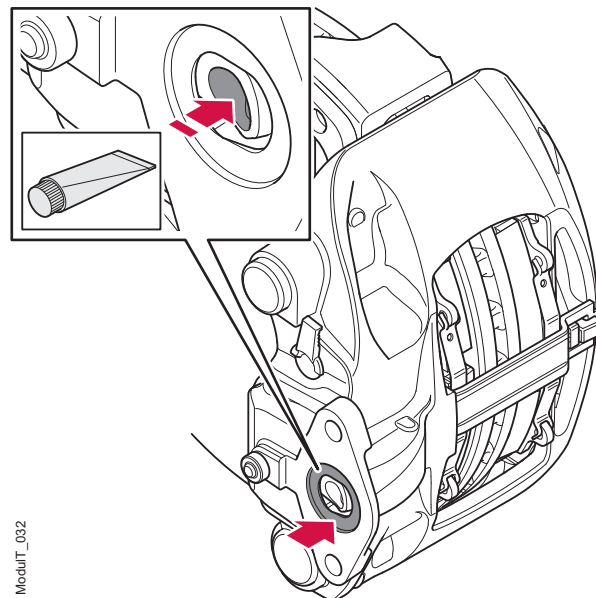

ModulT\_032

Figure 38. Pre-brake chamber mounting activity

5. Fit the new brake chamber (A) to the calliper (B) with nuts (E), see figure 39. Screw the nuts home first before torque tightening to ensure the brake chamber seats parallel.

Brake chamber fixation nut tightening torque is  $180\pm 20\text{Nm}$ .

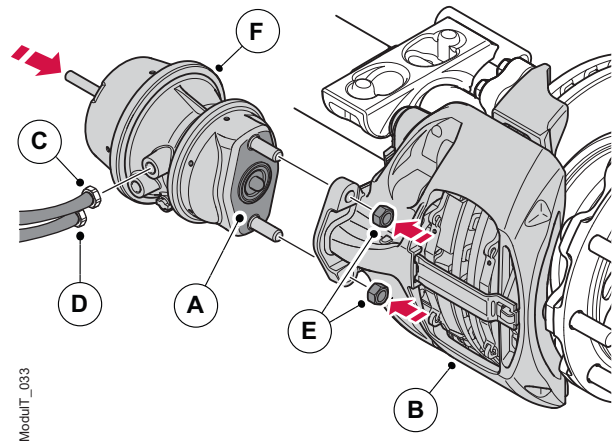

Figure 39. Installation of brake chamber items

**IMPORTANT!**  
**Do not mix up the hoses!**

6. Fit the brake chamber hose connection of the service brake (C) and if applicable the parking brake (D). If fitting both hoses, ensure connections (C) and (D) are the correct way around. See figure 39.



7. Remove the ventilation drain plug that faces downwards from the brake chamber housing, see figure 40. Also from the spring brake chamber if applicable.

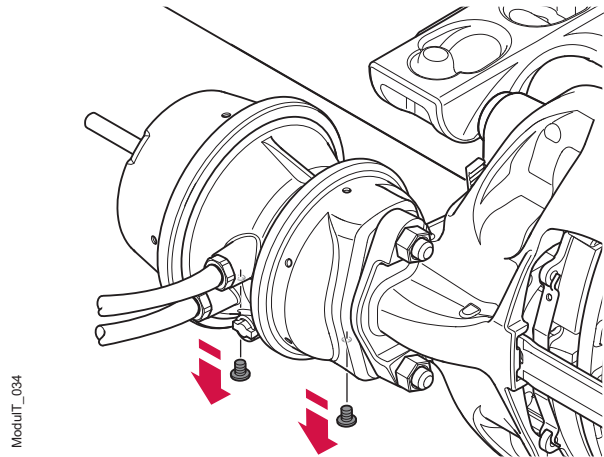

Figure 40. Remove the ventilation drain plug

**IMPORTANT!**

**Apply air to the parking brake. Make sure that there is sufficient air in the system (min. 6 bar).**

8. If applicable, release the parking brake and disengage the spring brake chamber's caging mechanism so that the spring is released. Min. 6 bar in compressed air system.
9. With the service brake engaged and, where applicable, with the parking brake released, check the brake chambers, hoses and connections for leaks or damage.

### 5.3.4 Final Procedure

To conclude this procedure read and follow chapters:

1. "3.3 Function Test" to ensure that the disc brake is working correctly;
2. "3.4 Final Procedure".

## 5.4 Replacement of Adjustment Screw Bellows

### 5.4.1 Initial Procedure

Read and follow the chapters below prior to removing the adjustment screw bellows:

1. "3.2 Initial Procedure";
2. "5.2.2 Remove Brake Pads";
3. "5.3.2 Remove Brake Chamber";
4. "5.7.2 Remove Disc Brake".

### 5.4.2 Remove Adjustment Screw Bellows

1. Fasten the disc brake securely in a vice with soft jaws, see figure 41 for clamping arrangement. Ensure that the jaws of the vice do not damage the disc brake.

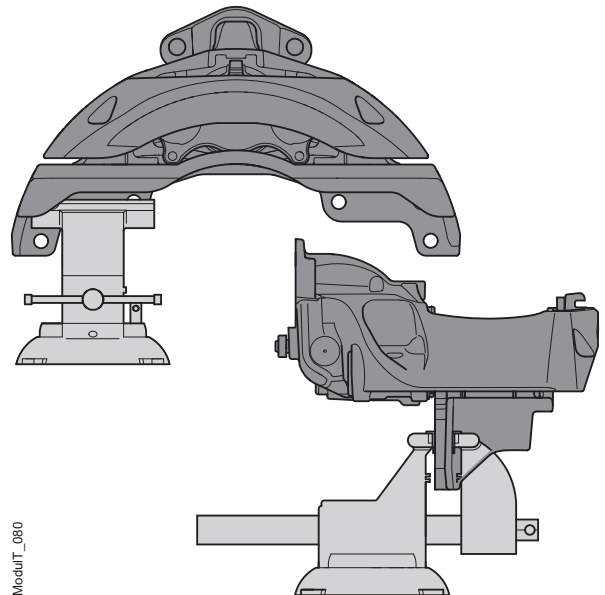

Figure 41. Clamping arrangement for replacing adjustment screw bellows

- Using Haldex special tool P/N 95232 (Torx 55), manually turn the reset shaft clockwise to extract the thrust plate (A). Continue extracting until the thrust plate unscrews fully and becomes detached from the adjustment screw, see figure 42.

The point at which the thrust plate becomes detached is when the gap between the thrust plate inner pad face and the calliper outer pad face becomes smaller than 52 mm.

Be careful when removing the thrust plate not to damage its internal threads or the external threads on the adjustment screw.

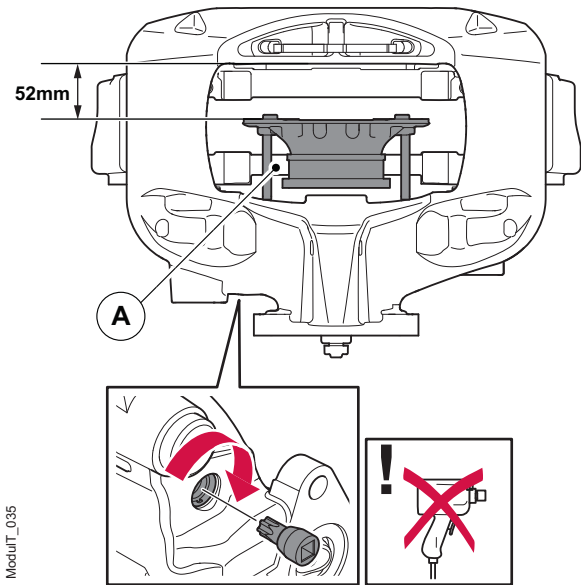

Figure 42. Extract the thrust plate

- Once the thrust plate becomes detached from the adjustment screw, by hand pull off the adjustment screw bellows from the thrust plate and calliper. Do not use any tools for this removal because damaging the sealing surfaces could cause water penetration leakage or seal corrosion upon re-assembly!

### 5.4.3 Cleaning

**IMPORTANT!**

**Use a vacuum cleaner to clean surfaces. Do not use compressed air!**

**IMPORTANT!**

**It is important to take care when using chemicals and/or cleaning tools (e.g. knife, brush, etc). This to avoid damage or displacement of hoses, seals and other components.**

**IMPORTANT!**

**Make sure that dirt and impurities do not enter the opening for the adjustment screw!**

Clean the thrust plate, the adjustment screw and the adjustment screw bellows sealing surfaces in the calliper. Ensure the parts are free from dirt, dust, debris, moisture and corrosion.

### 5.4.4 Install Adjustment Screw Bellows

1. Fasten the thrust plate in a vice fitted with soft jaws, see figure 43 for the clamping arrangement. Do not over tighten or damage the thrust plate whilst clamping!
2. Clean the internal threaded surface of the thrust plate.
3. Ensure that the contact surfaces between the thrust plate and the bellows are clean and free from dirt, moisture and corrosion.

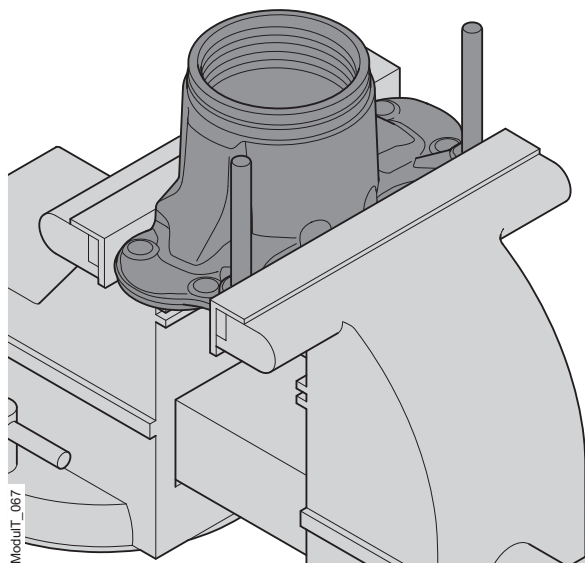

Figure 43. Clamping arrangement for thrust plate

#### **IMPORTANT!**

**Only use Haldex special tools where specified!**

4. By hand, using Haldex special tool P/N 95224 (C), firmly press the adjustment screw bellows (A) into position on the thrust plate (B), see figure 44.

Check that the bellows is correctly seated in position on the thrust plate.

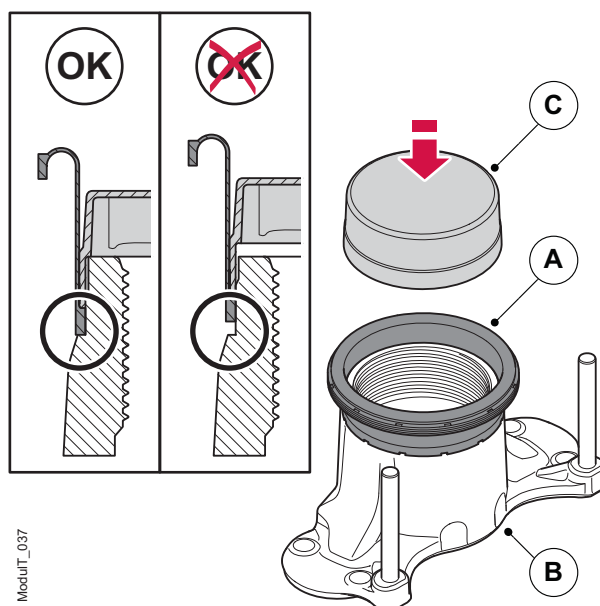

Figure 44. Fitting the adjustment screw bellows

5. Clean the external threaded surface of the adjustment screw. Ensure the parts are free from dirt, dust, debris, moisture and corrosion.
6. Apply the grease supplied with the spare parts kit, to the internal thread off the thrust plate and the external thread of the adjustment screw.
7. Remove the thrust plate from the vice.

**IMPORTANT!**

**Do not cross thread the thrust plate and the adjustment screw!**

8. By hand, hold the thrust plate in position against the adjustment screw. Insert Haldex special tool P/N 95232 (Torx 55) into the reset shaft and carefully turn anti-clockwise, as the adjustment screw turns, carefully engage the thrust plate threads onto the adjustment screw.

Be careful not to cross thread the parts, if the thread becomes tight or locks, turn the reset shaft clockwise to release the thrust plate, then try again.

A clicking sound will be heard and felt when turning the reset shaft anti-clockwise.

See figure 45.

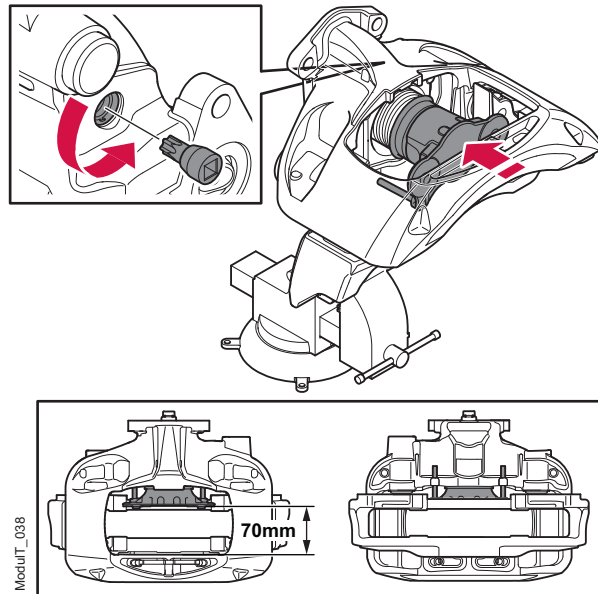

Figure 45. Loading the thrust plate

9. Shortly after the threads are engaged ensure that the two thrust plate guide pins correctly locate in their calliper holes.
10. Continue to retract the thrust plate until the dimension between the thrust plate inner pad face and the calliper outer pad face is 70 mm, as per figure 45.

**IMPORTANT!**

**Ensure that the bellows is correctly seated and undamaged. Failure to do so may compromise the life of the disc brake.**

11. Assemble Haldex special tool P/N 95225 and P/N 95226, load the assembled special tools into the calliper end of the adjustment screw bellows. See figure 46.
12. By hand, firmly press on the special tool with equal and parallel force so that the adjustment screw bellows is pressed into position within the calliper.
13. The special tool can be removed, rotated, and then reapplied to aid the equal and parallel bellows seating.

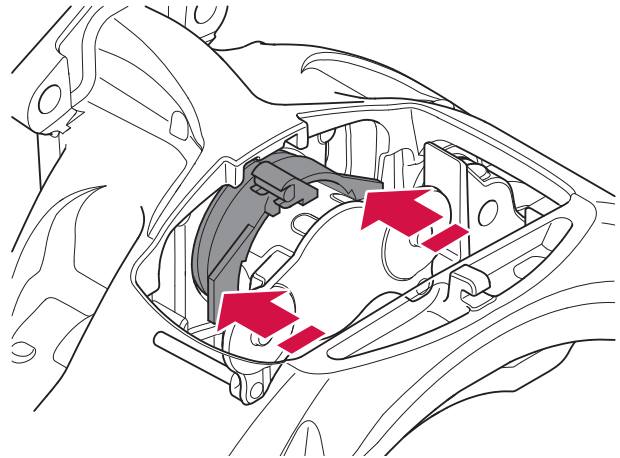

Figure 46. Pressing in the adjustment screw bellows

14. Remove the special tool. Check that the bellows is correctly seated all around within the calliper, see figure 47.

Also, re-check the bellows is seated correctly on the thrust plate, see previous figure 44.

Failure to seat the bellows correctly will compromise the life of the brake!

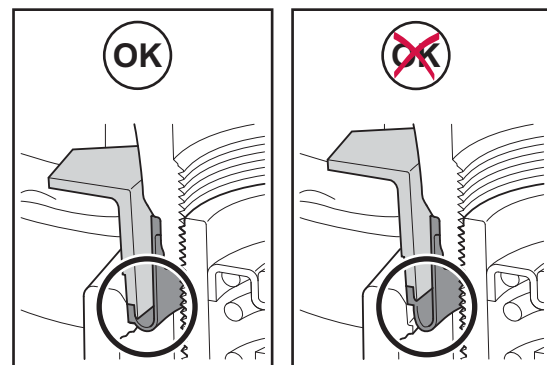

Figure 47. Adjustment screw bellows seated OK/NOK

15. Retract the thrust plate fully to its inner position by manually turning the reset shaft anti-clockwise. A clicking sound shall be heard and felt when retracting. The stop at fully retracted inner thrust plate position must be distinct, but do not exceed 20 Nm in torque or leave it tightened in this position.

### 5.4.5 Final Procedure

To conclude this procedure read and follow chapters:

1. "5.7.3 Install Disc Brake";
2. "5.2.3 Install Brake Pads";
3. "5.3.3 Install Brake Chamber";
4. "3.3 Function Test" to ensure that the disc brake is working correctly;
5. "3.4 Final Procedure".

## 5.5 Replacement of Slide Function Assembly

### 5.5.1 Initial Procedure

Read and follow the chapters below prior to removing the slide function assembly:

1. "3.2 Initial Procedure";
2. "5.2.2 Remove Brake Pads";
3. "5.3.2 Remove Brake Chamber";
4. "5.7.2 Remove Disc Brake".

### 5.5.2 Remove Slide Function Assembly

**IMPORTANT!**  
**Where specified only use Haldex Special Tools!**

1. Fasten the calliper securely in a vice with soft jaws, see figure 48 for clamping arrangement. Ensure that the jaws of the vice do not damage the calliper.

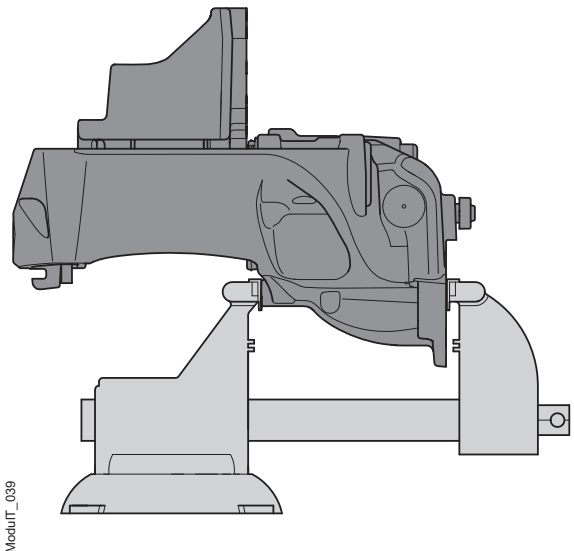

Figure 48. Clamping arrangement for replacing the slide function assembly

2. Use a small hammer and chisel to remove the leading and trailing protective cups (A), see figure 49. The protective cups are not to be re-used.

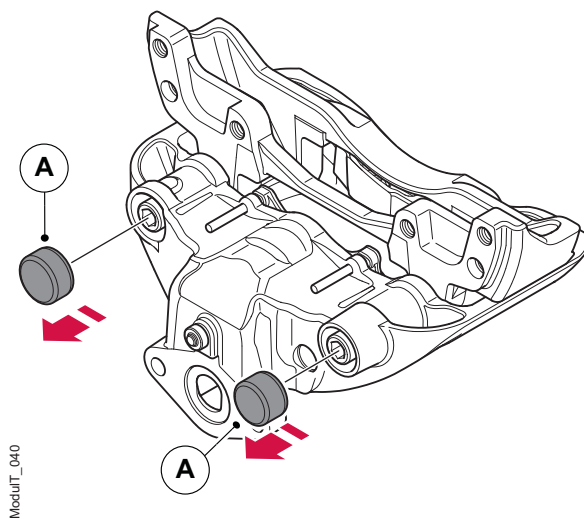

Figure 49. Remove slide protection cups .

3. Using Haldex special tool P/N95233 (3/4" long drive 14mm Insex), remove the two bolts (B), see figure 50. The bolts are not to be re-used.

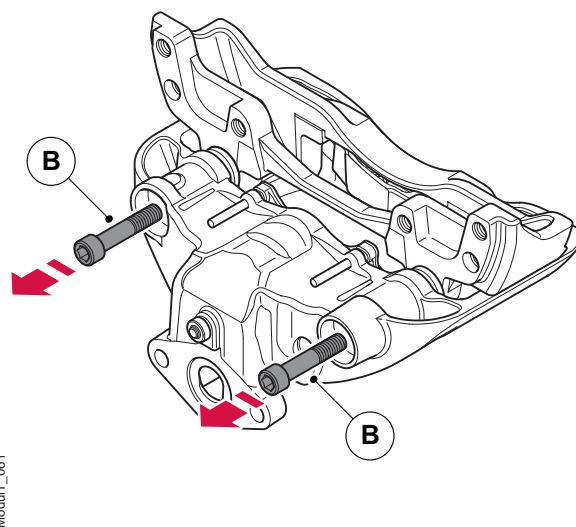
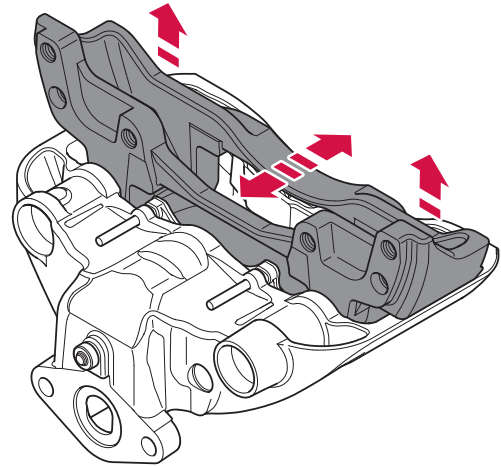

Figure 50. Remove the slide pin bolts



- Remove the carrier from the calliper by gently rocking the carrier to release it from the slide pins and bellows. Once released press slide pins back enough to be able to lift out the carrier, see figure 51.



ModulIT\_041

Figure 51. Remove the carrier

**IMPORTANT!****Be careful not to damage the slide pin bellows sealing surfaces in the calliper!**

- By hand push out and remove the leading slide pin (C) and the trailing slide pin (D), see figure 52.

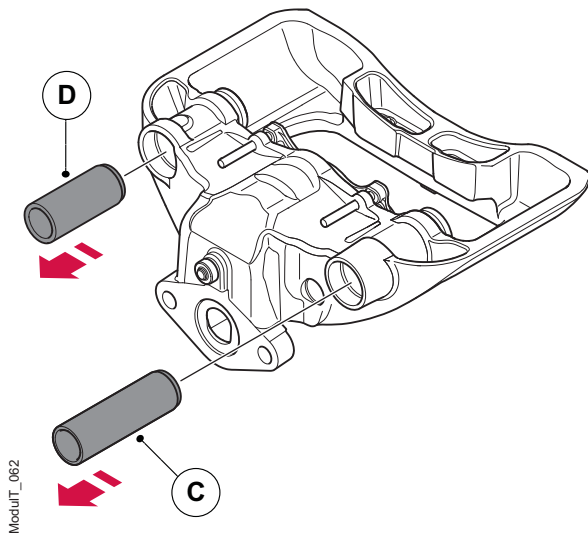

ModulIT\_062

Figure 52. Remove the slide pins

6. By hand, carefully remove the two slide pin bellows (E), see figure 53. If required, use a small screwdriver to assist by levering them out. Be careful not to damage the slide pin bellows sealing surfaces if using a tool to levering out the bellows.

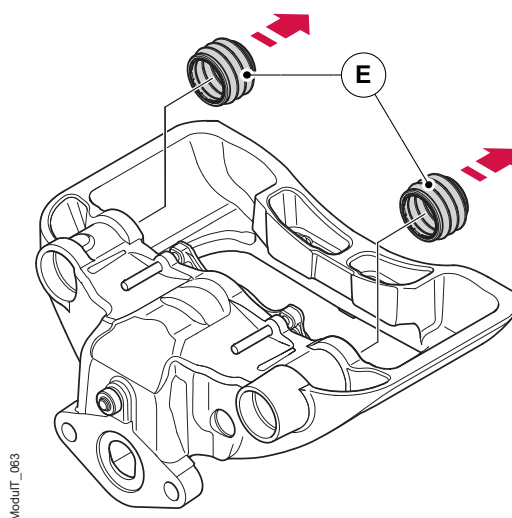

Figure 53. Remove the slide pin bellows.

7. Carefully follow steps 8 and 9 below to remove the two leading bearings (F) and the spacer (G) and trailing composite bushing (H), see figure 54.

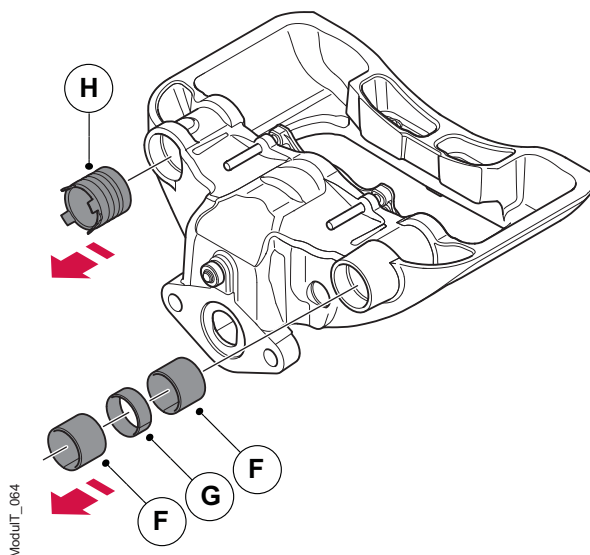

Figure 54. Remove the slide bearings and composite side bushing

8. To remove the two bearings (F) and the spacer (G) on the leading side, assemble in sequence Haldex special tool P/N's 95230, 95423, 95222, 95219 and 95220, as shown in figure 55.
9. Once fitted correctly, turn the threaded tool clockwise which will pull out the two bearings (F) and the spacer (G).

If required, rotate the mandrel P/N 95219 half way through the extraction process so the nut P/N 95220 can be held.

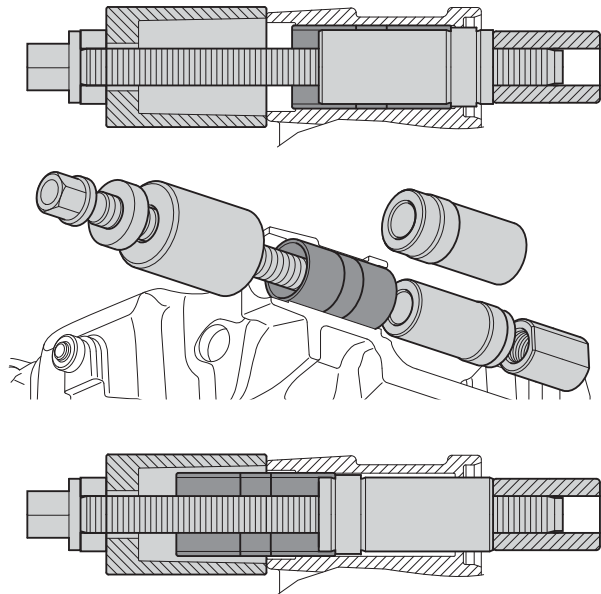

Figure 55. Remove the leading slide bearing

10. The composite bushing (H) on the trailing side should be removable by hand.
11. However if this is not possible, assemble in sequence Haldex special tool P/N's 95230, 95423, 95222, 95219 and 95220, as shown in figure 56.
12. Once fitted correctly, turn the threaded tool clockwise which will pull out the composite bushing.

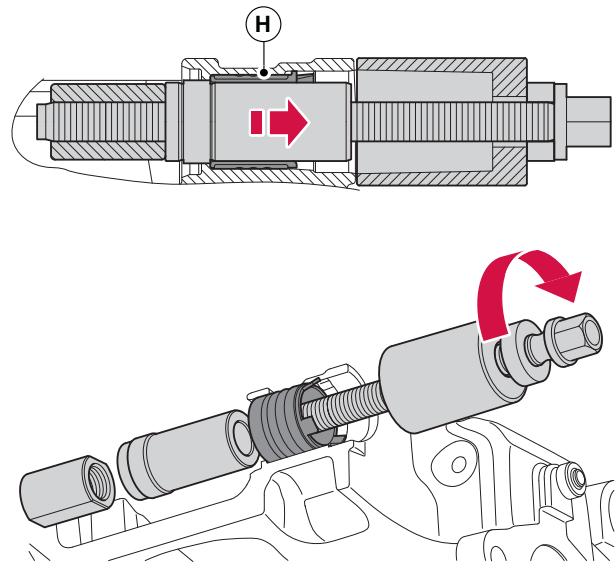

Figure 56. Remove the trailing side composite bushing

### 5.5.3 Cleaning

**IMPORTANT!**

Use a vacuum cleaner to clean surfaces. Do not use compressed air

**IMPORTANT!**

It is important to take care when using chemicals and/or cleaning tools (e.g. knife, brush, etc). This to avoid damage or displacement of hoses, seals and other components.

1. Clean the bearing/bush/bellows sealing surfaces of the calliper to ensure they are free from dirt, moisture, corrosion and damage. See figure 57.
2. If the sealing surfaces have lost their protective surface coating, apply/smear a small amount of general purpose grease over the whole area so when parts are refitted the grease will provide corrosion protection.

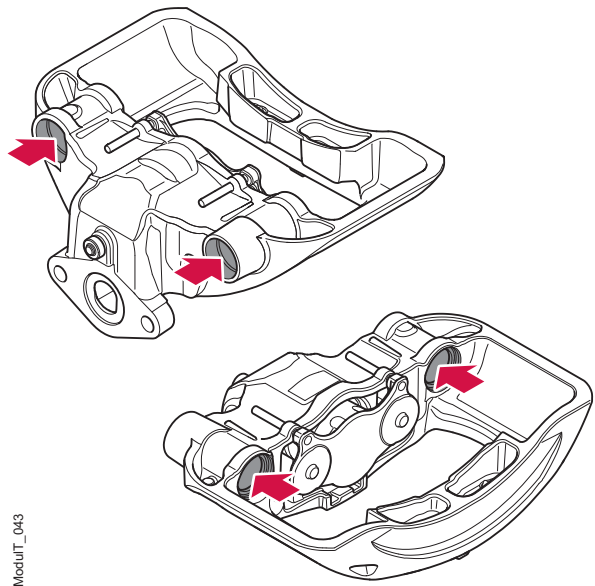

Figure 57. Clean the calliper bearing/bushing mating surfaces

### 5.5.4 Install Slide Function Assembly

**IMPORTANT!**  
**Only use Haldex special tools where specified!**

1. Carefully follow steps 8 and 9 below to install the two leading bearings (F) and the spacer (G) and trailing composite bushing (H), see figure 58.

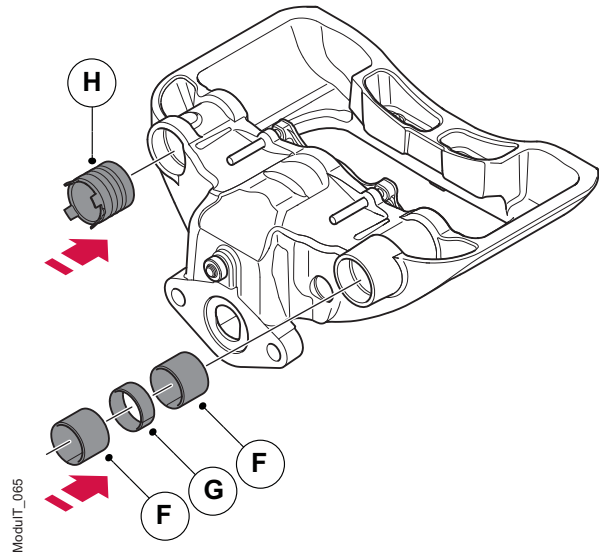

Figure 58. Install the leading slide bearings and trailing side bushing

2. To install the two new bearings (F) and the new spacer (G) on the leading side, assemble in sequence Haldex special tool P/N's 95230, 95423, 95219, 95221 and 95220, preloaded with the new parts, as shown in figure 59.
3. Once fitted correctly, turn the threaded tool clockwise which will pull into position the two bearings (F) and spacer (G) complete.

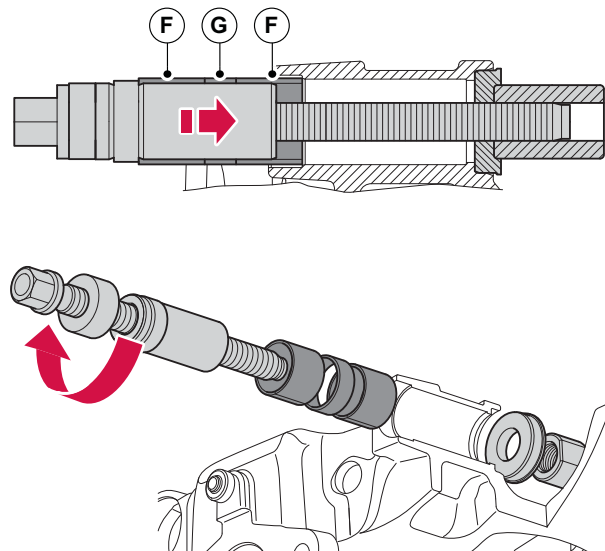

Figure 59. Tool assembly for leading slide bearings

4. Stop once the bearings are seated in their correct position up to the inside lip of the bearing location surface, see figure 60.

It is important the bearings are seated correctly but not over tightened as this may cause damage.

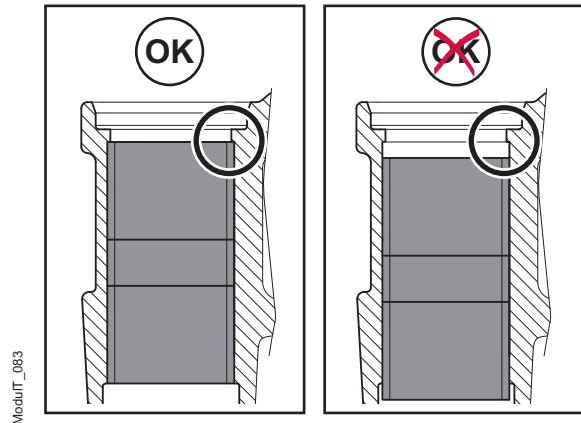

Figure 60. Leading side bearings installed OK/NOK

**IMPORTANT!**

**The trailing side composite bushing must be indexed correctly when being installed into position by hand. If not correctly indexed the slide function of the brake will not be correct.**

5. To install the new composite bushing (H) on the trailing side, by hand, push the composite bushing into place, until it bottoms out. Ensure the index lug locates correctly in the calliper slot, see figure 61.

No tools or high forces are required for this fitting process, nor should they be used! If used they may cause damage!

If the bushing is not indexed correctly the slide pin and protective cup may not fit!

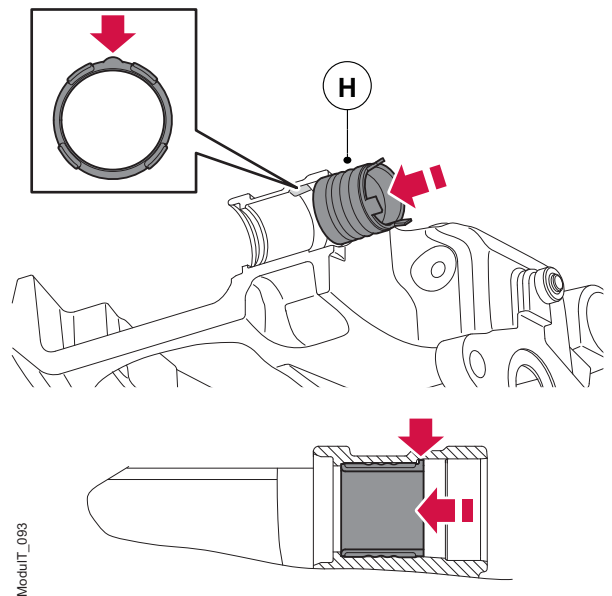

Figure 61. Inserting the trailing side composite bushing

**IMPORTANT!**

**When inserted the slide pin bellows must seat correctly, bottoming out against the calliper location shoulder.**

6. By hand, firmly push the two new slide pin bellows into their calliper locations ensuring that the bellows are seated correctly in position, see figure 62.

It is important to check that the bellows is correctly seated within the calliper, do so by looking inside the bellows to see their seating.

Failure to do so may compromise the sliding function of the brake.

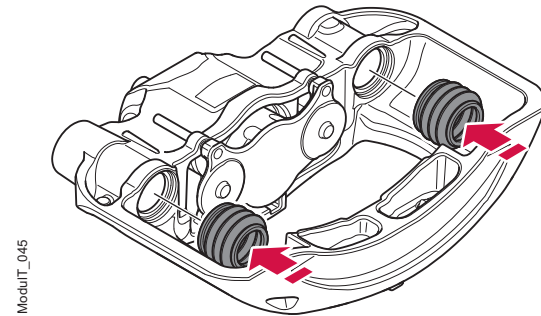
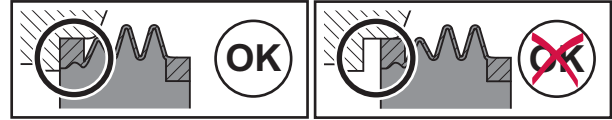

ModuIT\_045

Figure 62. Installing slide pin bellows.

7. By hand, insert the leading slide pin (C) into the bearings and the trailing slide pin (D) into the composite bushing, see figure 63.

The longer slide pin (C) is fitted into the leading side.

Note that one end of the slide pins has a machined groove, this side is inserted first.

No grease is required.

8. Check that the bellows location ring is fitted correct and in one piece. By hand, locate the bellows onto the end of the slide pins.

Ensure the bellows and the bellows location ring seat correctly on the slide pins. Failure to do so may compromise the sliding function of the brake.

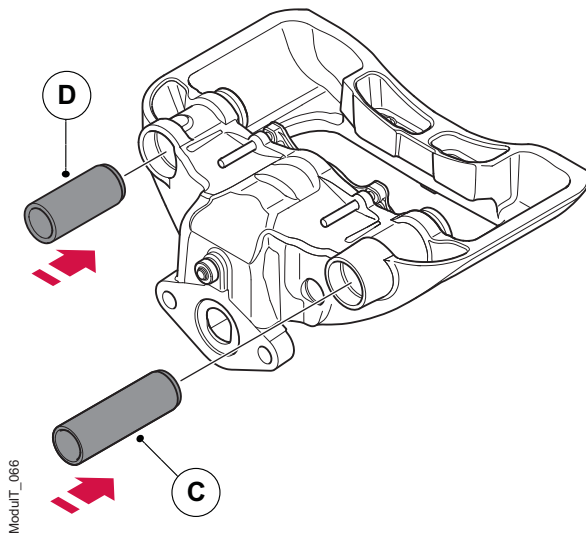

ModuIT\_066

Figure 63. Insert the slide pins.

9. Clean the brake pad contact surfaces on the carrier, the calliper and the thrust plate. A wire brush can be used but be careful not to damage any of the bellows. Do not grind!



**Never re-fit used bolts!**

10. Lift the carrier into position in the calliper ensuring that the slide pins fitted with bellows do not interfere or obstruct.

If necessary push out the slide pins slightly by hand whilst lowering in the carrier.

Hold the carrier in position whilst the two bolts are inserted and screwed home. See figure 64.

11. Using Haldex special tool P/N 95233 (3/4" long drive 14mm Insex), screw home and then tighten the slide pin bolts (B). Their torque setting is defined in chapter '6.2.2 Haldex ModulT ADB'.

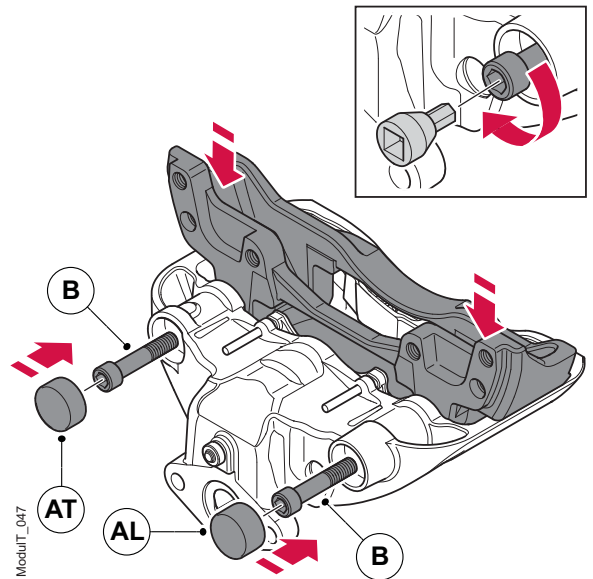

Figure 64. Refit the carrier and its fixing bolts

**IMPORTANT!**

**The protective cups are different sizes and when fitted must be seated correctly. The leading cup is smaller than the trailing cup. The leading cup must bottom out against the bearing and the trailing cup must bottom out against the calliper shoulder**



12. Carefully and squarely tap the protective cups (AT and AL) in place into the calliper using a soft headed mallet.

Note that the cups are different sizes, the larger cup is fitted to the trailing side (AT) and the smaller to the leading side (AL).

The leading protective cup (AL) seats raised from the casting surface whilst the trailing protective cup (AT) sits nearly flush.

13. Do not strike the cups hard or at an angle as this may damage them and therefore compromise the sliding function of the brake.
14. Ensure the protective cups are correctly seated and bottomed out, see figure 65.

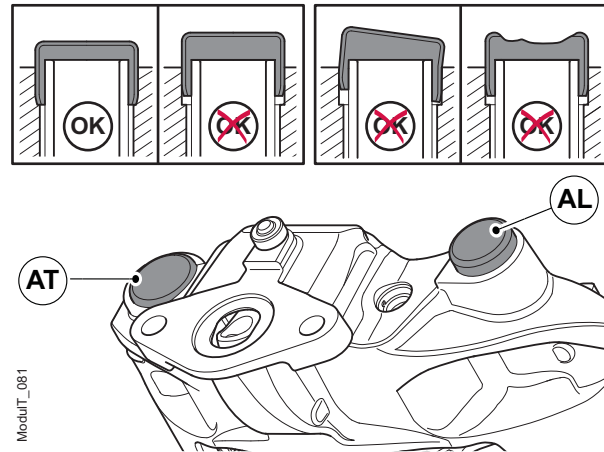

Figure 65. Correctly seating the protection cups

### 5.5.5 Final Procedure

To conclude this procedure read and follow chapters:

1. "5.7.3 Install Disc Brake";
2. "5.2.3 Install Brake Pads";
3. "5.3.3 Install Brake Chamber";
4. "3.3 Function Test" to ensure that the disc brake is working correctly;
5. "3.4 Final Procedure".

## 5.6 Replacement of Reset Shaft Complete

### 5.6.1 Initial Procedure

Read and follow chapter "3.2 Initial Procedure" prior to removing the reset shaft complete.

**IMPORTANT!**  
**Only use Haldex special tools where specified!**

### 5.6.2 Remove Reset Shaft Complete

1. If necessary remove dirt, dust and other possible debris from around the reset shaft area. Ensure the area is clean prior to removing the reset shaft protection plug.
2. Remove the reset shaft protection plug (A).
3. Insert Haldex special tool P/N 95210 and pull out the reset shaft (B) with x-ring complete, see figure 66.

The x-ring is always fitted to the reset shaft and never removed.

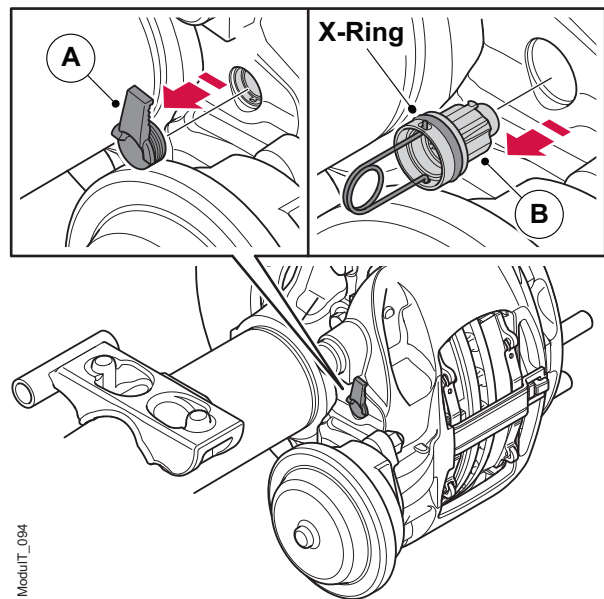

Figure 66. Removing the reset shaft

### 5.6.3 Install Reset Shaft Complete

1. Clean the reset shaft location surfaces in the calliper housing. Ensure the areas are free from dirt, dust, debris, moisture and corrosion.
2. Insert Haldex special tool P/N 95232 (Torx 55) into the new reset shaft and by hand insert it into the calliper. Whilst doing so make sure the x-ring is correctly in place.

The reset shaft complete with x-ring already fitted is supplied ready lubricated, no additional grease or other lubrication is required.

3. Push the reset shaft into position by hand, no impact or high forces are required as they may damage the reset shaft.

The reset shaft will click into its position in the center of the gear wheel when fully engaged. See figure 67.

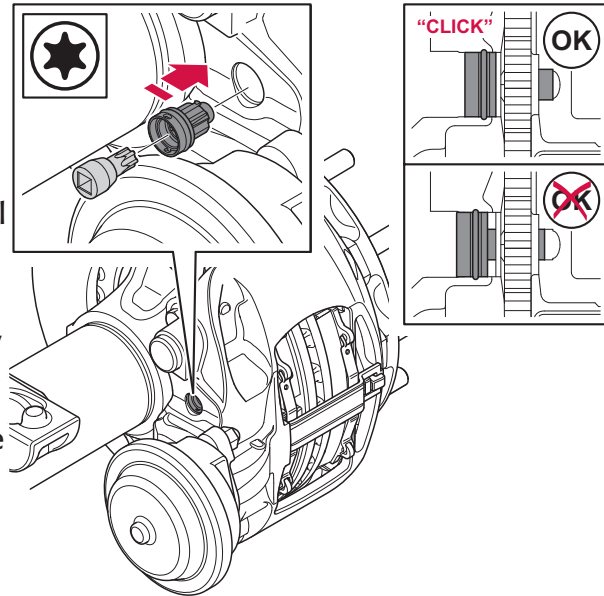

Figure 67. Installing the reset shaft

### 5.6.4 Final Procedure

To conclude this procedure read and follow chapters:

1. "3.3 Function Test" to ensure that the disc brake is working correctly;
2. "3.4 Final Procedure".

## 5.7 Replacement of Disc Brake

### 5.7.1 Initial Procedure

Read and follow the chapters below prior to removing the disc brake.

1. "3.2 Initial Procedure";
2. "5.2.2 Remove Brake Pads", instruction 1 through to 5 only;
3. "5.3.2 Remove Brake Chamber".

### 5.7.2 Remove Disc Brake

#### **IMPORTANT!**

**Do not remove the disc brakes retaining bolts until the brakes weight is supported by the lifting straps!**

1. Refit the old pad retainer by first locating the housing end in the calliper aperture, then locating the pad retainer slot over the calliper latch, finally slide the pad retainer under the calliper latch until the pad retainer spring pops into locking position. See figure 68.



**Check that the spring bracket is correctly engaged!**

2. Attach a lifting strap around the pad retainer. Tension the lifting strap so taking the full weight of the brake.

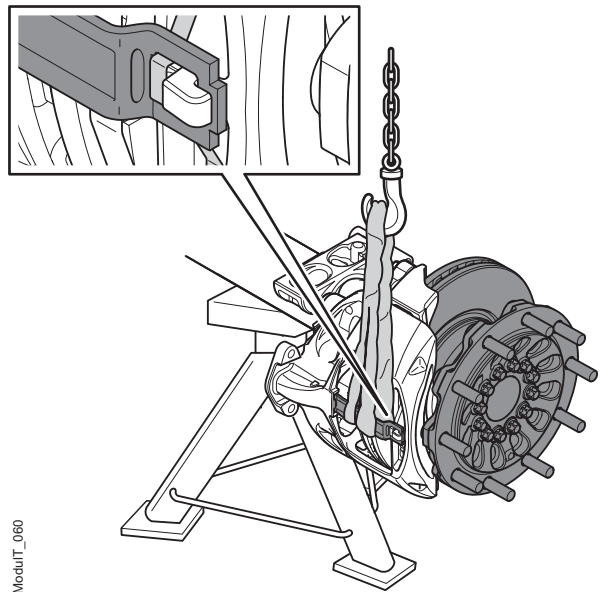

ModulT\_060

Figure 68. Disc brake removal

3. Remove the retaining bolts holding the disc brake and lift away from the axle.

### 5.7.3 Install Disc Brake

1. Clean the mating faces of the new disc brakes carrier and axle. Ensure the faces are free from dirt, debris, moisture and corrosion.
2. Fit the old pad retainer spring, then refit the old pad retainer by first locating the housing end in the calliper aperture, then locating the pad retainer slot over the calliper latch, finally slide the pad retainer under the calliper latch until the pad retainer spring pops into locking position.



**Check that the spring bracket is correctly engaged!**

3. Attach a lifting strap around the pad retainer and then lift the brake into position.
4. Follow the vehicle/axle manufacturer's recommendations for fitting/tightening the retaining bolts, or follow the general method described hereafter.
5. Fit and screw home the retaining bolts, alternating from side to side of the carrier.
6. Tighten all retaining bolts to the torque settings defined by the vehicle/axle manufacturers specifications.
7. Remove the lifting strap, old pad retainer and pad retainer spring. Scrap the old pad retainer and pad retainer spring as they are not to be used again.

### 5.7.4 Final Procedure

To conclude this procedure read and follow chapters:

1. "5.2.3 Install Brake Pads";
2. "5.3.3 Install Brake Chamber";
3. "3.3 Function Test" to ensure that the disc brake is working correctly;
4. "3.4 Final Procedure".

# 6 Specifications

The Haldex ModuLT Air Disc Brake come both left and right handed, it is important the correct hand is fitted in relation to the normal wheel/disc rotation.

Figure 69 below shows a general overview of both variants and their relation to the normal wheel/disc rotation, shown as a red arrow, and their leading (AL) and trailing (AT) slide functions.

Each calliper also has a rotation arrow formed on the cast surface where the pad retainer seats on the inboard side, see figure 69.

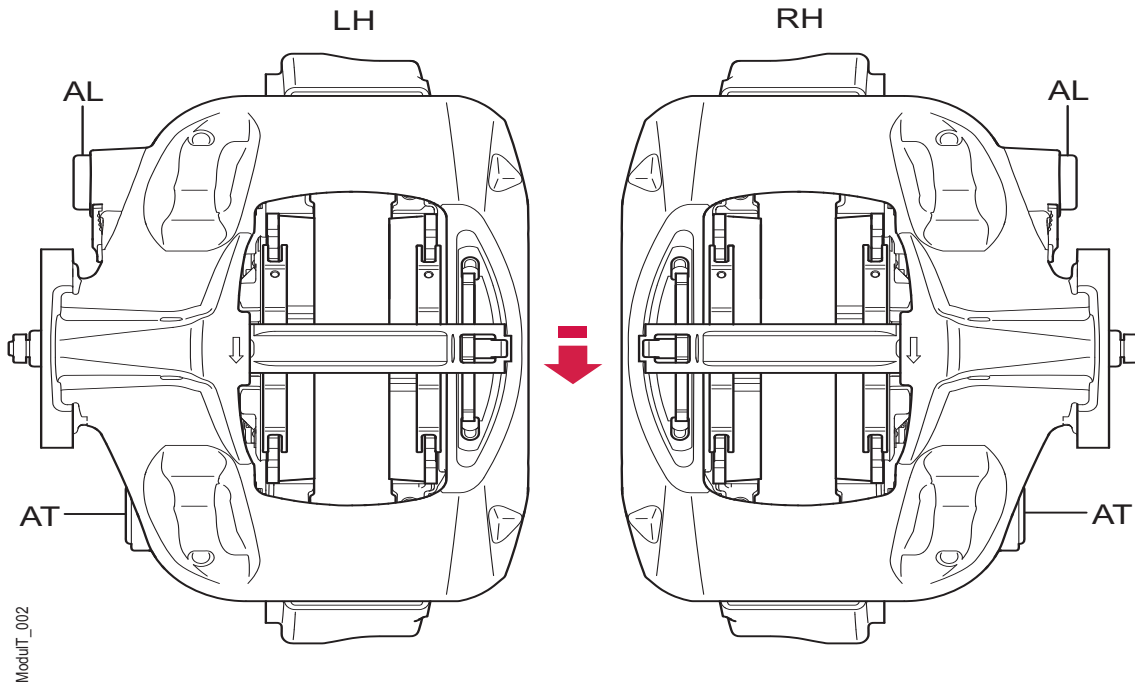

Figure 69. Haldex ModuLT orientation

## 6.1 Wear Limits

- Brake Pads, min. lining thickness ..... 2 mm
- Brake Pads, max. uneven wear ..... ±1.5 mm
- Brake disc, min. thickness ..... 37 mm

## 6.2 Tightening Torques

### 6.2.1 General

Follow the vehicle/axle manufacturers recommendations.

### 6.2.2 Haldex ModuLT ADB

	DBT22LT
Bolts x2 for slide pins	180 Nm + 70°
Brake chamber fixation nuts	180 ±20 Nm

## 7 Tools

### 7.1 Haldex ModuT Tool Kit complete

Part Number (P/N) 95231

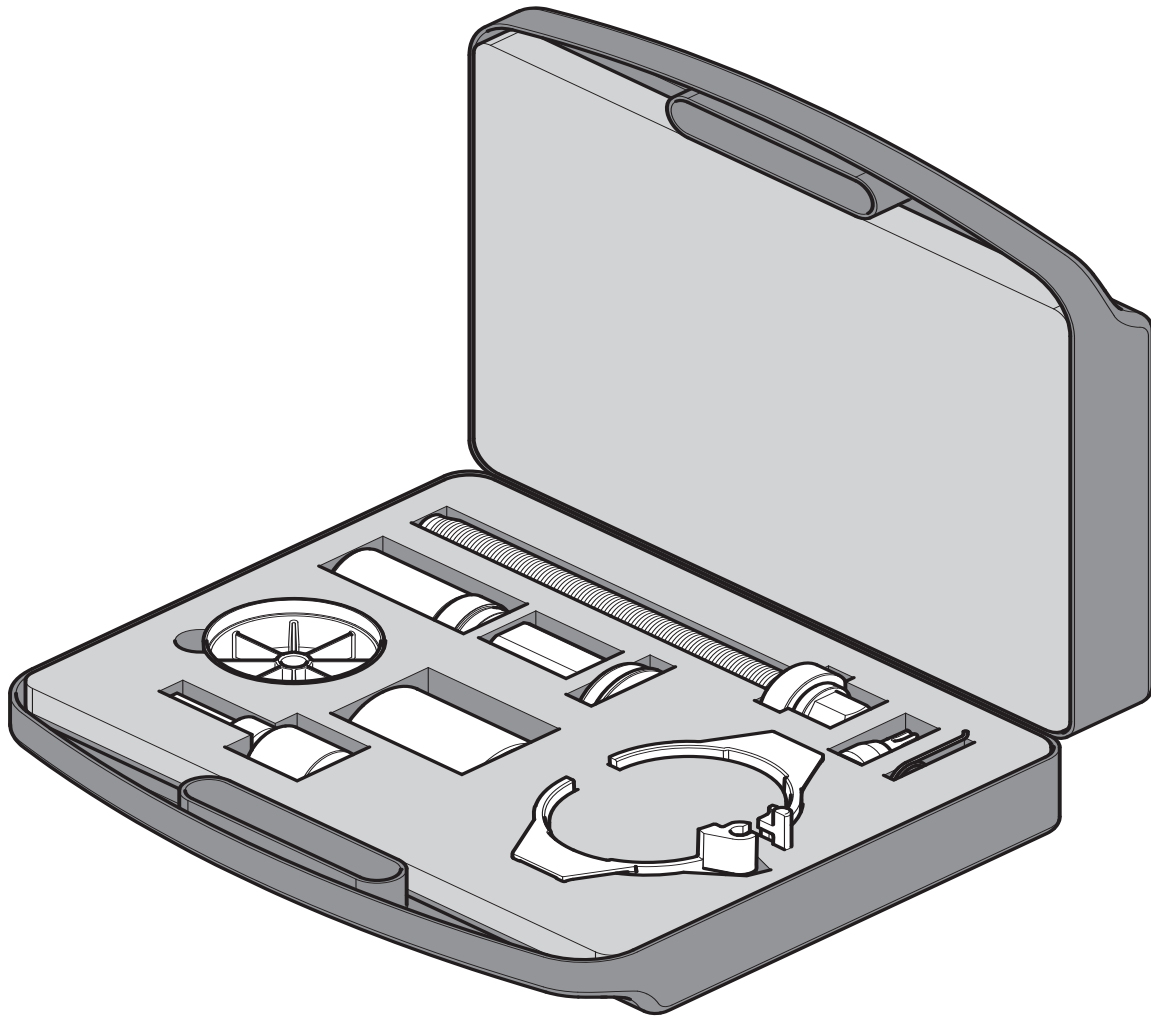

Figure 70. Haldex ModuT tool kit

## 7.2 Special tools for Haldex Modult.

Contents of tool kit Haldex P/N 95231.

P/N 95219	Mandrel for the removal and assembly of slide function Bearings and Composite Bushing
P/N 95220	Nut for the removal and assembly of slide function Bearings and Composite Bushing
P/N 95221	Clamp washer for the assembly of slide function Bearings and Composite Bushing
P/N 95222	Cup for the removal of slide function Bearings and Composite Bushing
P/N 95224	Mounting tool for adjustment screw bellows onto the thrust plate
P/N 95225	Mounting tool for adjustment screw bellows into the calliper - Left
P/N 95226	Mounting tool for adjustment screw bellows into the calliper - Right
P/N 95233	3/4" drive long reach 14mm Insex for slide pin bolts
P/N 95232	3/8" drive Torx T55 for the Reset Shaft
P/N 95210	Special tool for removing Reset Shaft Complete
P/N 95230	Threaded spindle used with Pull-out/Pull-in tool pieces
P/N 95423	Axial bearing used with the threaded bar



## 8 Fault Finding



**Take all necessary Safety Precautions before wheel removal!  
Read the Safety Precautions carefully.  
The vehicle manufacturer's instructions shall also be followed!**

Symptoms	Actions
See the relevant chapters for remedial measures	
<b>No or low braking effort</b>	
• Are the pads worn out?	• Replace the pads.
• Is pad/disc clearance OK?	• Conduct initial setting + function checks.
• Is the brake disc OK?	• Replace the brake disc (See vehicle manufacturer's instructions.)
• Is air pressure in the brake chamber OK? (Measure with a pressure gauge at the brake chamber)	• Implement remedial measures according to vehicle manufacturer's instructions.
• Has the drain plug been removed from the brake chamber housing?	• Remove the drain plug located at the lowest point of the brake chamber.
• Does the mechanism and calliper move freely?	• Conduct initial settings and function check.

<b>The brakes pull to one side</b>	
• Are the pads worn on one side?	• Replace the pads.
• Is pad/disc clearance OK?	• Conduct initial setting + function checks.
• Can the pads move freely in the carrier?	• Remove the brake pads, clean the pads, carrier and calliper.
• Is there the same pressure in both brake chambers of the axle during braking? (Measure with pressure gauge at the brake chambers.)	• See the vehicle manufacturer's instructions for more information.
• Has one of the drain plugs been removed from the brake chamber housing?	• Remove the drain plug located at the lowest point.

Symptoms	Actions
<b>Brakes are binding/not releasing/have heat-damaged components /brake pads wear out quickly.</b>	
<ul style="list-style-type: none"> <li>Does brake pressure remain in the brake chamber when the brakes are released?</li> </ul>	<ul style="list-style-type: none"> <li>See the vehicle manufacturer's instructions for information.</li> </ul>
<ul style="list-style-type: none"> <li>Are all of the spring brake chambers released when the parking brake is off?</li> </ul>	<ul style="list-style-type: none"> <li>See the vehicle manufacturer's instructions for information</li> </ul>
<ul style="list-style-type: none"> <li>Is pad/disc clearance OK?</li> </ul>	<ul style="list-style-type: none"> <li>Conduct initial setting + function checks.</li> </ul>
<ul style="list-style-type: none"> <li>Can the pads move freely in the carrier?</li> </ul>	<ul style="list-style-type: none"> <li>Remove the brake pads, clean the pads, carrier and calliper.</li> </ul>
<ul style="list-style-type: none"> <li>Is the calliper slide function OK?</li> </ul>	<ul style="list-style-type: none"> <li>Conduct check slide function.</li> </ul>
<ul style="list-style-type: none"> <li>Is the wheel bearing clearance OK?</li> </ul>	<ul style="list-style-type: none"> <li>See the vehicle manufacturer's instructions for information.</li> </ul>
<ul style="list-style-type: none"> <li>Has one of the drain plugs been removed from the brake chamber housing?</li> </ul>	<ul style="list-style-type: none"> <li>Remove the drain plug located at the lowest point.</li> </ul>
<ul style="list-style-type: none"> <li>Has valve adjustment/brake force distribution been carried out correctly?</li> </ul>	<ul style="list-style-type: none"> <li>Adjust brake valves/carry out brake force adaptation. Refer also to vehicle manufacturer's instructions.</li> </ul>
<ul style="list-style-type: none"> <li>Uneven pad wear or pads wearing out too quickly?</li> </ul>	<ul style="list-style-type: none"> <li>Work through the inspections chapter to ensure the brake is functioning correctly and thus identify any operational problems requiring rectification.</li> <li>Also check that genuine Haldex brake pads are being used, only use Haldex original spare parts!</li> <li>Check that the correct brake pad friction material is being used for the specific application.</li> <li>Check the brake harmonisation between the truck and trailer is correctly setup.</li> </ul>

<b>Noise/ vibrations from the brake</b>	
<ul style="list-style-type: none"> <li>Can the pads move freely in the carrier?</li> </ul>	<ul style="list-style-type: none"> <li>Remove the brake pads, clean the pads, carrier and calliper, then refit.</li> </ul>
<ul style="list-style-type: none"> <li>Are there non-permitted cracks/grooves on the brake disc?</li> </ul>	<ul style="list-style-type: none"> <li>Probably need to change the brake disc. See the vehicle manufacturer's instructions for more information.</li> </ul>
<ul style="list-style-type: none"> <li>Is the brake disc's run-out within specified parameters?</li> </ul>	<ul style="list-style-type: none"> <li>If not then probably need to change the brake disc. See the vehicle manufacturer's instructions for more information.</li> </ul>

# 9 Component List and Exploded view

## 9.1 Component List

### **Hallex ModuLT Air Disc Brake**

010	Air Disc Brake Assemblies Complete - Left Hand & Right Hand
020	Carrier
030	Bearings - Leading Slide Function
040	Spacer
050	Leading Slide Pin
060	Slide Pin Bolt
070	Leading Protective Cup
080	Composite Bushing - Trailing Slide Function
090	Trailing Slide Pin
100	Trailing Protective Cup
120	Reset Shaft Complete
130	Reset Shaft Protection Plug
140	Bellows - Slide Function
150	Brake Pads
160	Pad Springs
170	Spring Bracket
180	Pad Retainer
190	Adjustment Screw Bellow
210	Thrust Plate

## 9.2 Exploded view

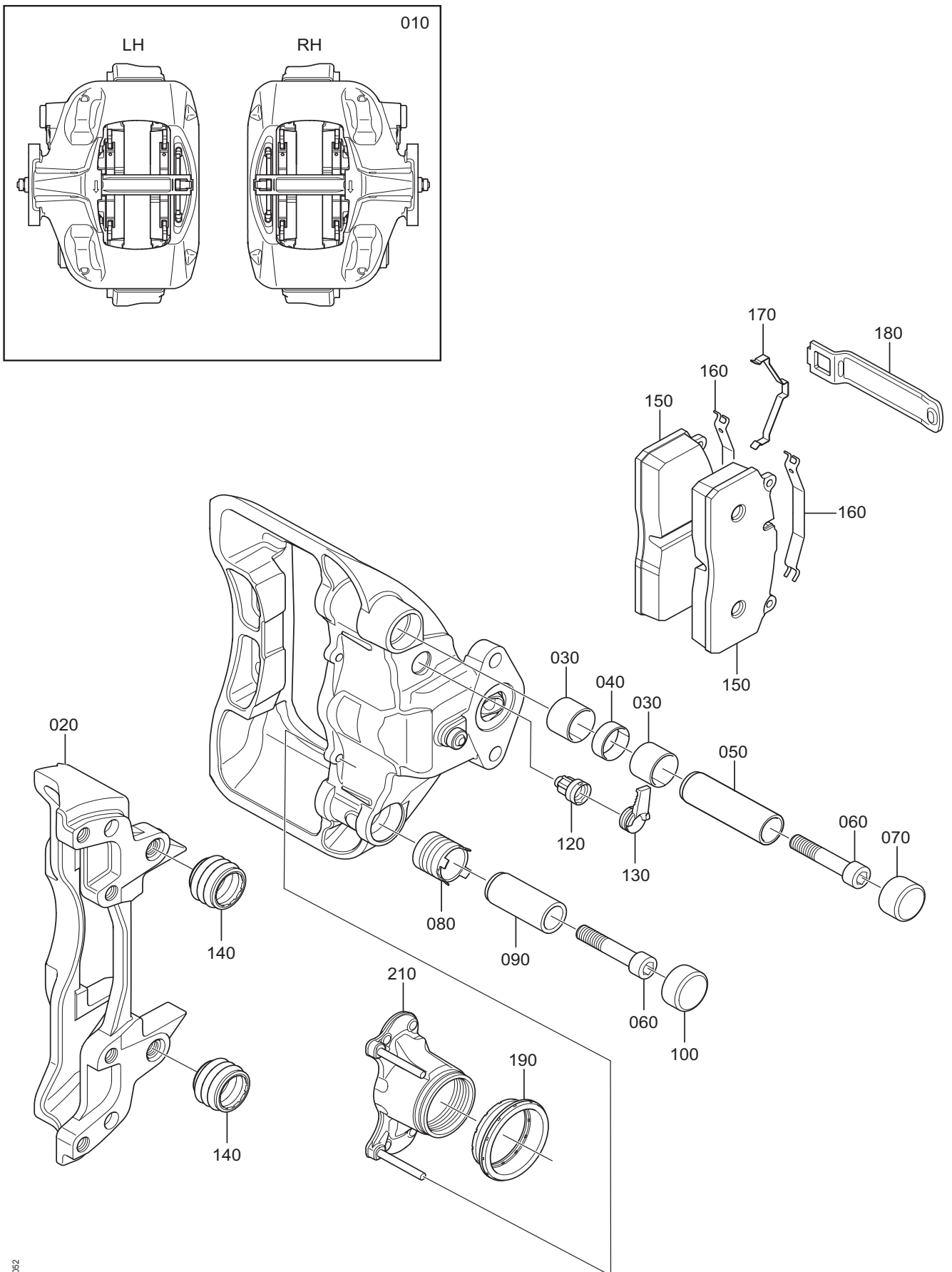

Haldex develops and provides reliable and innovative solutions with focus on brake and air suspension products to the global commercial vehicle industry. Listed on the Stockholm Stock Exchange, Haldex has annual sales of 3.7 billion SEK and employs 2,200 people.

#### **Austria**

Haldex Wien Ges.m.b.H.  
Vienna  
Tel.: +43 1 8 69 27 97  
Fax: +43 1 8 69 27 97 27  
E-Mail: info.AT@Haldex.com

#### **Belgium**

Haldex N.V.  
Balegem  
Tel.: +32 9 363 90 00  
Fax: +32 9 363 90 09  
E-Mail: info.BE@Haldex.com

#### **Brazil**

Haldex do Brasil Ind. E Com. Ltda  
São Paulo  
Tel.: +55 11 213 55 000  
Fax: +55 11 503 49 515  
E-Mail: info.BR@Haldex.com

#### **Canada**

Haldex Ltd  
Cambridge, Ontario  
Tel.: +1 519 621 6722  
Fax: +1 519 621 3924  
E-Mail: info.CA@Haldex.com

#### **China**

Haldex Vehicle Products Co. Ltd.  
Suzhou  
Tel.: +86 512 8885 5301  
Fax: +86 512 8765 6066  
E-Mail: info.CN@Haldex.com

#### **France**

Haldex Europe SAS  
Weyersheim (Strasbourg)  
Tel.: +33 3 88 68 22 00  
Fax: +33 3 88 68 22 09  
E-Mail: info.EUR@Haldex.com

#### **Germany**

Haldex Brake Products GmbH  
Heidelberg  
Tel.: +49 6221 7030  
Fax: +49 6221 703400  
E-Mail: info.DE@Haldex.com

#### **Hungary**

Haldex Hungary Kft.  
Szentlőrincváta  
Tel.: +36 29 631 300  
Fax: +36 29 631 301  
E-Mail: info.hu.eu@Haldex.com

#### **India**

Haldex India Limited  
Nasik  
Tel.: +91 253 6699501  
Fax: +91 253 2380729  
E-Mail: info.IN@Haldex.com

#### **Italy**

Haldex Italia Srl.  
Biassono (Milan)  
Tel.: +39 039 47 17 02  
Fax: +39 039 27 54 309  
E-Mail: info.IT@Haldex.com

#### **Korea**

Haldex Korea Ltd.  
Seoul  
Tel.: +82 2 2636 7545  
Fax: +82 2 2636 7548  
E-Mail: info.HKR@Haldex.com

#### **Mexico**

Haldex de Mexico S.A. De C.V.  
Monterrey  
Tel.: +52 81 8156 9500  
Fax: +52 81 8313 7090

#### **Poland**

Haldex Sp. z o.o.  
Praszka  
Tel.: +48 34 350 11 00  
Fax: +48 34 350 11 11  
E-Mail: info.PL@Haldex.com

#### **Russia**

OOO "Haldex RUS"  
Moscow  
Tel.: +7 495 747 59 56  
Fax: +7 495 786 39 70  
E-Mail: info.RU@Haldex.com

#### **Spain**

Haldex España S.A.  
Granollers  
Tel.: 34 93 84 07 239  
Fax: 34 93 84 91 218  
E-Mail: info.ES@Haldex.com

#### **Sweden**

Haldex Brake Products AB  
Landskrona  
Tel.: +46 418 47 60 00  
Fax: +46 418 47 60 01  
E-Mail: info.SE@Haldex.com

#### **United Kingdom**

Haldex Ltd.  
Newton Aycliffe  
Tel.: +44 1325 310 110  
Fax: +44 1325 311 834  
E-Mail: info.GBAy@Haldex.com

Haldex Brake Products Ltd.  
Redditch  
Tel.: +44 1527 499 499  
Fax: +44 1527 499 500  
E-Mail: info.GBRe@Haldex.com

#### **USA**

Haldex Brake Products Corp.  
Kansas City  
Tel.: +1 816 891 2470  
Fax: +1 816 891 9447  
E-Mail: info.US@Haldex.com

©2011, Haldex AB. This material may contain Haldex trademarks and third party trademarks, trade names, corporate logos, graphics and emblems which are the property of their respective companies. The contents of this document may not be copied, distributed, adapted or displayed for commercial purposes or otherwise without prior written consent from Haldex.

